

G-Series Positive Displacement - Gear Flow Meters

Operational Manual G004, G015, G045, G105, G240



Model G004



Model G015



Model G045



Model G240



Model G105



Table of Contents

Before You Install.....	page 3
Meter General Description.....	page 4
Transmitter General Description.....	page 5
Meter Specifications	page 5
Transmitter Specifications.....	page 5
Transmitter Specifications Temp	page 6
Available Designs	page 6
Installation.....	page 7
Do's & Don'ts.....	page 8
Piping Diagram	page 8
Electrical Installation - Wiring.....	page 9-10
Pressure Drop Charts	page 11
Optional Heater Block Details.....	page 13
Contact for Repairs & Calibration Services	page 13
Part number matrix.....	page 14
Limited Warranty	page 15
Custom Instructions for Hazardous Locations/Explosion Proof Housing: http://www.maxmachinery.com/content/explosion-proof-installation-instructions	

DO NOT ATTEMPT TO INSTALL OR START FLOW METER WITHOUT READING THIS ENTIRE MANUAL

Max Machinery, Inc. (MMI) reserves the right to make changes to the product in this Instruction Manual to improve performance, reliability, or manufacturability. Consequently, contact MMI for the latest available specifications and performance data. Although every effort has been made to ensure accuracy of the information contained in this Instruction Manual, MMI assumes no responsibility for inadvertent errors.

Before You Install



Thank you for choosing to install a Max Machinery precision flow meter. To ensure the best experience please take a moment to read through this manual prior to installation.

When you purchased this meter a flow engineer helped determine the best meter for you based on many of the factors that will be reviewed on the following pages. If you have any questions about installation or operation please don't hesitate to call Max Machinery, Inc. at 707-433-2662

When you are ready to install there will be a few tools you will need:

Meter Installation:

- The meter and transmitter
- A signal cable (available from factory)
- The display or signal processing device
- Indicator Manual
- Calibration Certificate
- Bypass plumbing supplies

Many Max meters are installed and operate for decades, so having the following information in your records may prove useful. We have provided this outline as a starting point.

Process Temperatures _____ Fluid Viscosity _____

Operating Range _____ Line Pressure _____

Max Sales # or PO # _____ Installation Date _____

Meter Model # _____ Meter Serial # _____

Notes: _____

Meter General Description



While gear meters are traditionally based on a design similar to a conventional hydraulic pump, the G Series of flow meters has been engineered to increase signal resolution, prevent internal cavitation and greatly reduce the pressure drop required to move fluid through the gears.

Max flow meters and transmitters are calibrated at the factory as a matched set. This ensures the highest accuracy and allows for quick setup in the field. For field installations where the transmitter has not been setup with a meter at the factory, an optional serial interface kit is available to provide full access to all configuration options and parameters.

Solid state sensors are used to detect the position of a driven magnet inside the Max Flow Meter. Changes in position are tracked by a microprocessor, which generates an output frequency proportional to the flow rate. Advanced signal processing provides both fine angular resolution (0.36 degrees rotation per pulse) and rapid response (output updated every 1 ms). The G-Series transmitter uses modern sensor technology coupled with advanced signal processing to deliver new levels of performance and reliability.

Flow Meter Features

- Capable of operating at high pressures (425 bar/6000 psi).
- Compatible with a wide range of fluid types and viscosities.
- Can operate at high temperatures with a suitable high temperature transmitter.

Transmitter Features

- High resolution measurement -Analog Output: Configured output ranges to any value within ± 10 Vdc or ± 20 mA.
- Frequency Output: Configured output resolution of 1 to 1000 pulses per revolution.
- Linearization of up to 16 points to fully describe the flow meter's output curve and achieve the highest system linearity over the meter's entire operating range.



Max Model G004

Transmitter General Description

Max transmitters are designed to work with the entire family of Max Flow Meters to provide extremely precise flow measurement in a cost effective package. Different options of industrial housings or IP66 rated explosion proof enclosures, combined with a choice of one-part and two-part, high temperature designs with remote electronics cover a wide range of application environments - from the laboratory to harsh industrial processes.

Compensation Algorithm - Compensates for variations in Hall sensor and flow meter characteristics to provide a stable, undamped output that accurately represents the instantaneous flow rate. This feature is factory set when the meter and transmitter are mated together. If the transmitter is changed, the compensation can be performed via a button on the circuit board.

Anti-Dither Buffer - Masks the false output that may occur at very low flow rates in the presence of vibration or hydraulic noise. If the meter reverses direction the output signal will be interrupted for a user selected portion of a meter rotation. Reverse flow exceeding the buffer setting will result in an output proportional to reverse flow rate. The buffer quantity can be set from 1% to 100% of a revolution.

Meter Specifications



Model	G004	G015	G045	G105	G240
¹ Maximum flow rate					
Liters/min:	4	15	45	105	240
Gal/min:	1	4	11.9	28	64
Maximum pressure (psi)	-----414 bar (6000 psi)-----				see below
² Maximum temperature	----- 2 part: 225°C (435°F) -----				
³ Recommended filtration	10 micron	15 micron	20 micron	20 micron	30 micron
Displacement (cc/rev)	1.8	4.2	13.5	38	133
Weight (kg)	1.2	1.8	3.7	7.7	21
Typical k-factor (pulses/cc)	500	200	70	25	7
NPT Port size	1/8"	3/8"	1/2"	3/4"	1" to 280 bar (4000 psi)
SAE Port Size	#4	#6	#8	#10	#16 to 425 bar (6000psi)

¹ For viscosities of 100 cps or more, derate per pressure drop curves for higher viscosities.

² Standard transmitter capable to 90°C (195°F)

³ Some materials may have different filter requirements, consult factory.

Transmitter Specifications

Supply Voltage & Current	5-26 Vdc @ 30 mA typical
Frequency output	12Vdc @ 90 mA typical
Analog output	24Vdc @ 45 mA typical
Analog Resolution	Adjustable without recalibration to any range of +/- 20mA - Models ending in "A1" and "B1" +/- 10 Vdc - Models ending in "C1" and "D1"

Frequency Model Specifications

Output (5.0 Volt Supply)	No Load 0.00 / 4.80 Volts 2.5K Load to Common 0.00 / 4.60 Volts 2.5K Load to +5 Volts 0.25 / 4.80 Volts
Short Circuit Current (1)	45 mA
Output Impedance	100 Ω
Rise/Fall Time	0.2 μ Sec
Output Update Rate(2)	1 ms
Min/Max Frequency	0-60 kHz
Resolution	1 - 1000 pulses/rev
Ambient Temperature Range	Transmitter (Storage) -40°C to 85°C (-40°F to 185°F) Transmitter (Operation) (3) -40°C to 80°C (-40°F to 175°F)
Maximum Temp, Process Fluid (20°C Ambient, 5V supply)	(Standard Model) 90°C (195°F) (High Temp Model) 155°C (310°F) (Ultra High Temp Model) 225°C (435°F)
Anti-dither Range Default	50% Revolution of Meter for unidirectional (software selectable from 1 - 100% of 1 revolution). 2% for bi-directional meters
Signal Filtering	Software selectable from 1ms to 250ms time constant

(1) Continuous Short Circuit is not recommended. The output current should not exceed 10 mA

(2) Events are seen as output transitions 1 ms after they occur

(3) Temperature of metered fluid will affect transmitter temperature, see graph

Transmitter Temperature graph

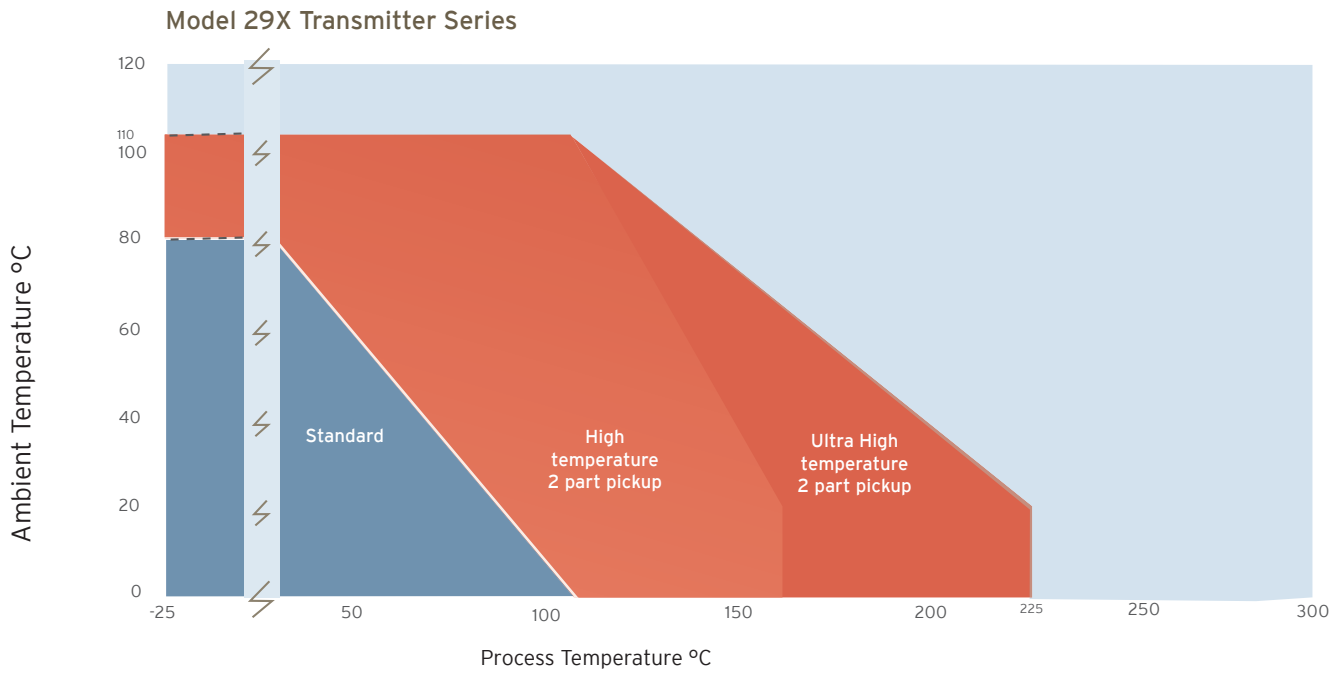

Available Designs



G004 Standard



G004 2-Part Pickup



G004 Ex-Proof

Installation



Prior to installing the flow meter remove the storage caps from the ports and look carefully into each port of the meter. Ensure that no dirt or foreign particles have gotten into the ports of the meter. Make sure that adequate filtration exists upstream of the flow meter and that no contaminants exist in the line between the filter and flow meter. It is recommended that the flow meter be connected to the circuit by means of unions close to the flow meter to allow easy removal.

A by-pass valve should be installed between the inlet and outlet ports in parallel to the flow meter to allow flow through the system in the event that the flow meter becomes blocked by foreign material.

The preferred orientation for the meter is to place the transmitter to the side of the flow meter. Such an installation ensures that bubbles will not accumulate within the meter. In a high pressure installation, the compression and expansion of gas bubbles from the bearing pockets may create undesirable side forces on the gears. Mounting the meter with the transmitter to the side will purge the air from the meter. This orientation is also preferred as it reduces the amount of heat that rises from the meter into the transmitter circuitry.

The following items and conditions should be considered:

Line and Bypass Valves: These valves allow filter cleaning or flow meter removal without completely shutting the system down and draining the lines. They also allow system start up under conditions which could damage the meter; such as: air in the lines, high temperature materials, or initial line surges.

Filtration: Clearances between the gears and internal wall are typically 0.001" to 0.002". Any dirt present in the system can jam or damage the unit. A 10 micron filter (such as a Max 381 Series stainless steel unit) is generally recommended, although materials with very high viscosities may require a coarser filter. For bidirectional flow applications, use a filter on each side of the flow meter. Materials with fibrous or non abrasive particulate matter may have to be run without filters. Follow the recommendation of your Max Sales Engineer or consult our Technical Service Department.

Inlet and Outlet Ports: Use the "IN" port as the inlet for the most predominant flow direction. Install the flow meter on the discharge side of the pump whenever possible. Excessive vibration at the meter should be avoided.

High Temperatures: Mount the meter so that the transmitter is below or to the side of the meter. This minimizes heat transfer by convection from the flow meter to the transmitter. The transmitter is the most heat sensitive element in the system and the transmitter manual should be consulted for specific limits. An optional fluid heater block can be used on the flow meter to keep it at operating temperature during standby conditions. For substances that are solid at room temperature, the block may be required to keep the material molten and flowing through the meter.

Clean Plumbing: Before installing the flow meter, clean the inside of the pipe line with compressed air or steam (especially when using new pipe). Don't use water, steam, or compressed air on the meter itself!

Do's & Don'ts



DO:	DON'T:
<ul style="list-style-type: none"> • Install a bypass line around the meter • Clean the filter on a regular basis • Purge air from the meter before operating your system (Flowing near the meters maximum flow rate for a given viscosity will purge air bubbles. Tilting, tapping or shaking the meter at lower flow rates will also dislodge entrapped air) 	<ul style="list-style-type: none"> • Run water or aqueous solutions through the meter (except the 234 Series of meters) • Put steam or compressed air through the meter. • Disassemble the meter (Air may over-speed and damage the meter) • Apply excessive differential pressure across the meter • Exceed the maximum flow rates or pressure ratings for your meter • Let materials solidify in the meter • Try to pump through the meter if it contains frozen material. Re-melt the material completely before trying to pump through the flow meter.

Piping Diagram

Horizontal Installation

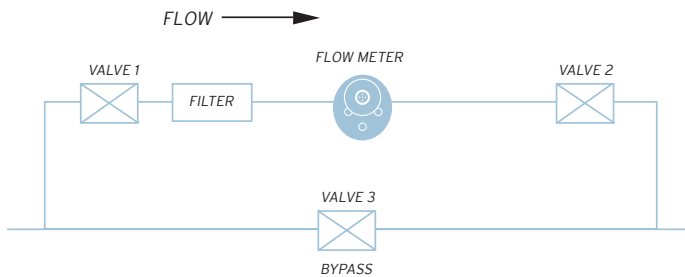

Horizontal Two-Way Flow

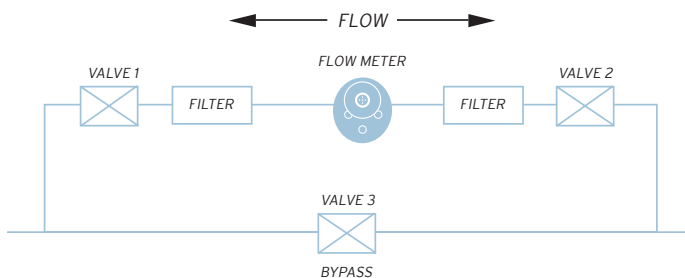

Vertical Installation

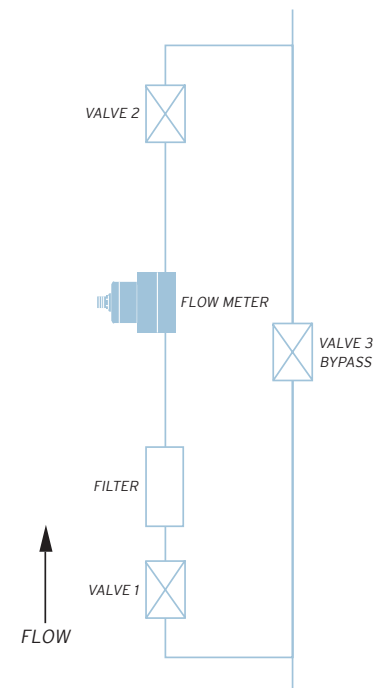

Electrical Installation - Wiring

Removal note: The transmitter does not need to be removed from the flow meter for any field servicing or adjustments. Normally, the flow meter and transmitter are shipped back to the factory for calibration or service as a unit. If the transmitter needs to be removed from the flow meter for installation, be sure to retighten the transmitter snugly in order to ensure proper sensor alignment.

Mechanical Installation

1. The transmitter is attached to the flow meter's threaded magnet shield. Hand tighten only. (~ 3 ft-lb)
2. The transmitter lid has four thread paths. To realign the cable, remove the lid and rotate up to 180° and retighten using an alternate starting point. Tighten to compress the O-ring seal.

Removal

1. Remove electrical connections
2. Unscrew transmitter, using a wrench if necessary.



WARNING

Installation and removal should only be facilitated by trained personnel
Verify transmitter output type (ANALOG or FREQUENCY) before wiring, inappropriate wiring could result in damaging the circuit.

Moisture Seal Protection

On all models, the housing is designed as a liquid and vapor-tight enclosure. There is an O-ring seal at the lid of the housing – these need to be fully seated. A properly sealed transmitter will prevent the formation of damaging moisture inside the housing.

Turck connector model: The connector is sealed to the lid at the factory and is ready for use.

NPT Model: To ensure a moisture-tight seal, apply appropriate sealant to the threads at installation.

Electrical Installation - Wiring

This page covers the installation of transmitters with 5-pin, M12 style connectors only. For hazardous location devices with 1/2" conduit connections, please refer to the EXInstall sheet.

Frequency Output Transmitters (Models ending with P..N/- or Q..N/-)

	Turck® Connector		
	PCA Label	Pin #	Mating Cable Wire Color
Power (+5 to 26 Vdc)	V+	1	Brown
Common	Com	4	Black
Pulse Output	Ph A	2	White
Output Phase B (Quad only)	Ph B	5	Grey
Case Ground	Case	3	Blue

Current Sinking Wiring

(Model # 295-600-000 and versions ending with S/-)

A current sinking device uses the transmitter's transistor output to act as a switch. A positive DC voltage must be applied to the transmitter's output pin (#2). When the pulse output is triggered, this voltage will be grounded to zero volts by the transmitter. Warning: Use a 5k ohm resistor to limit current if your system does not have any other means to limit the current into the transmitter.

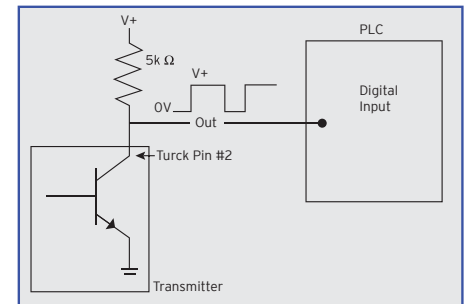

Voltage or Current Analog Transmitters (Models ending with A/-, B/-, C/- or D/-)

	Turck® Connector		
	PCA Label	Pin #	Mating Cable Wire Color
Power *	V+	1	Brown
Common	Com	4	Black
Signal Output (+)	Sig	5	Grey
Signal Output (-)**	Ret	2	White
Case Ground	Case	3	Blue

* Analog transmitters with part numbers 29X-XXX-000 or ending in A/- or C/- are 24Vdc power. Part numbers 29X-XXX-100 or ending in B/- or D/- are 12Vdc power.

** To minimize signal noise, analog output transmitters are fully isolated. If your PLC does not ground the negative signal input, there is a risk of a ground shift that could drive the signal out of the range of detection. To prevent this from occurring please consider installing a 10k pull down resistor between Common and Signal Output (-).

Pressure Drop Charts



Model G004 Flow Meter

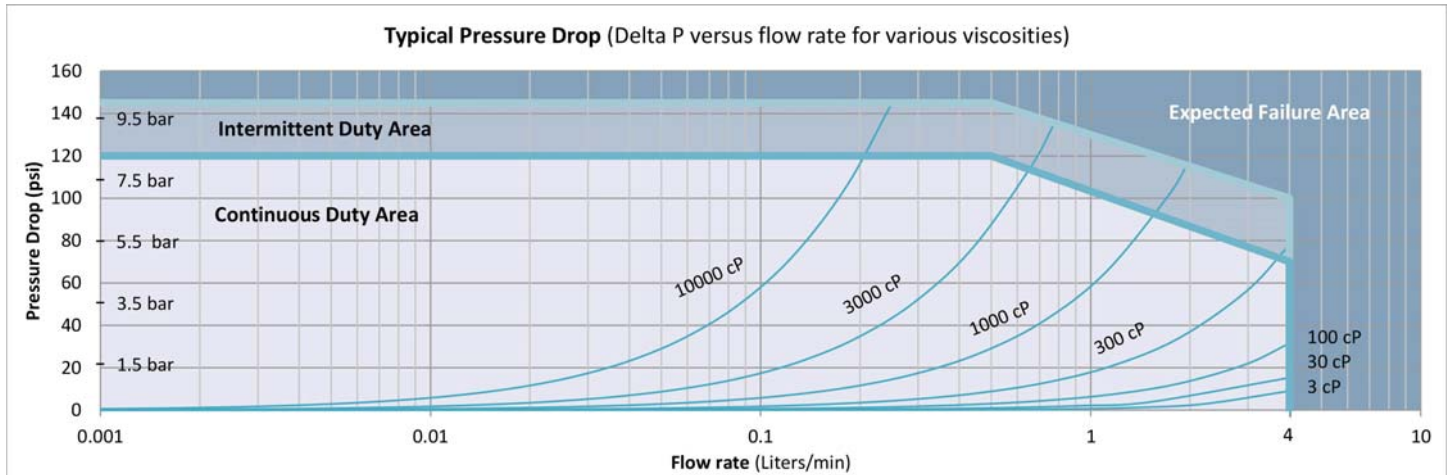

Model G015 Flow Meter

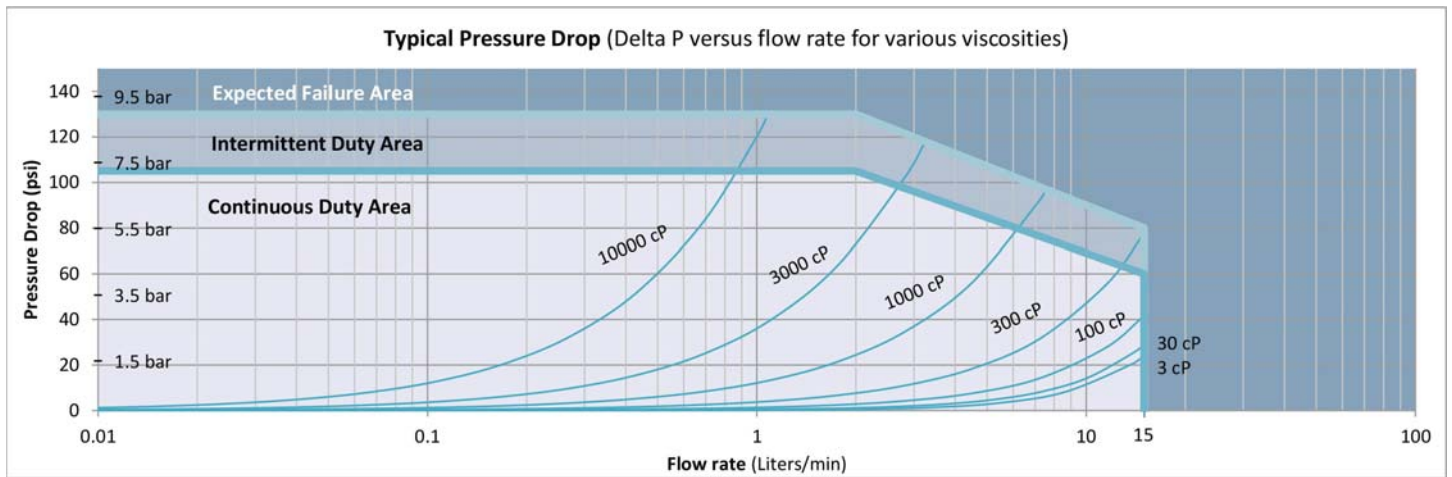

Model G045 Flow Meter

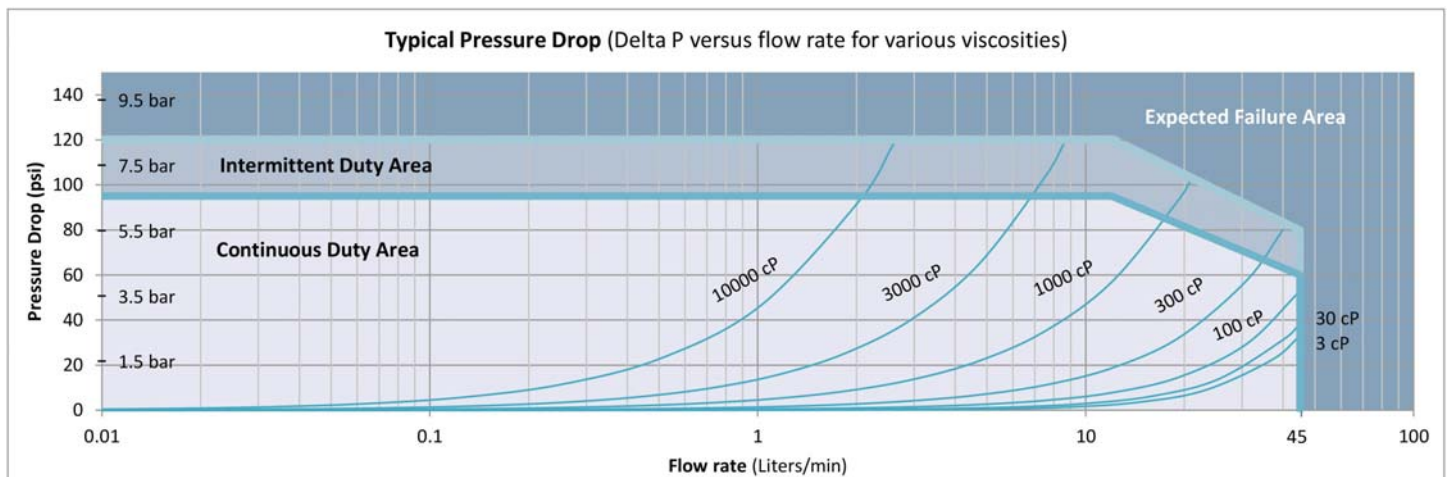

Pressure Drop Charts - continued

Model G105 Flow Meter

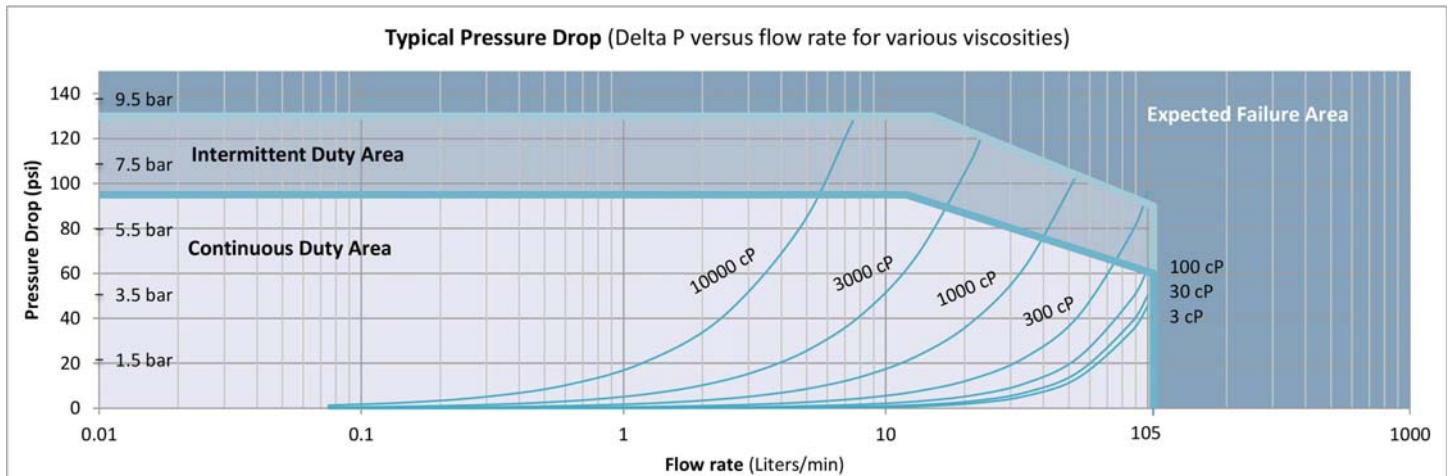

Model G240 Flow Meter

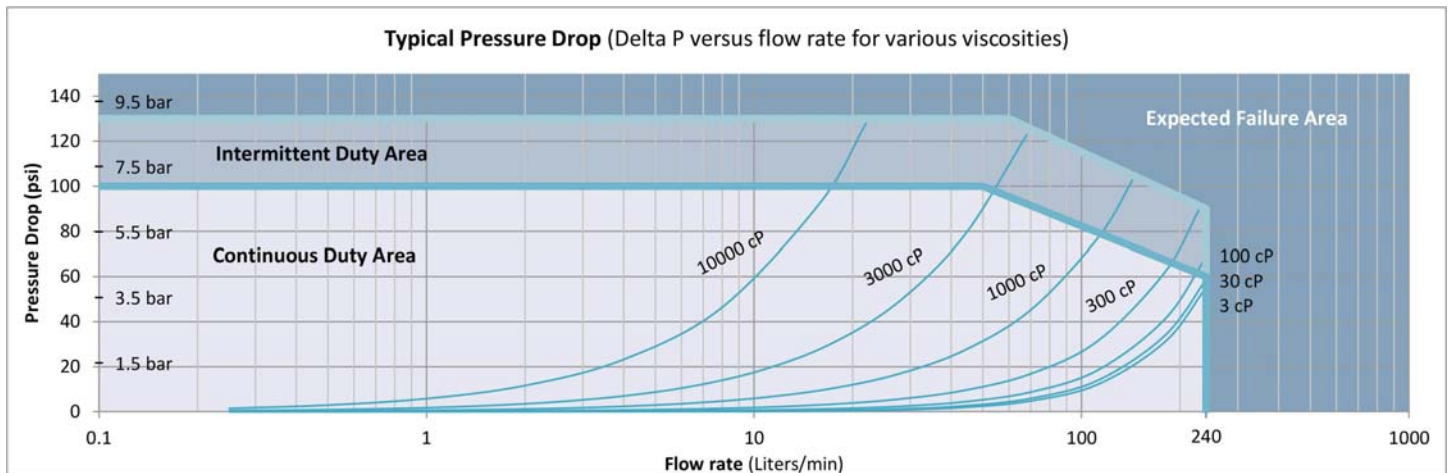

Optional Heater Block Details

Temperature probe holes (all models)

1/8" NPT

1/16" NPT

Liquid trace ports

G004, G015 1/4" NPT

G045, G105 3/8" NPT

G240 (Qty 2) 3/8" NPT

Electric Cartridge requirements

G004 3/8" x 1"

G015 3/8" x 1.3"

G045 1/2" x 2.1"

G105 1/2" x 3.1"

G240 (Qty 2) 1/2" x 4.7"

Heater block for G015 (typical)

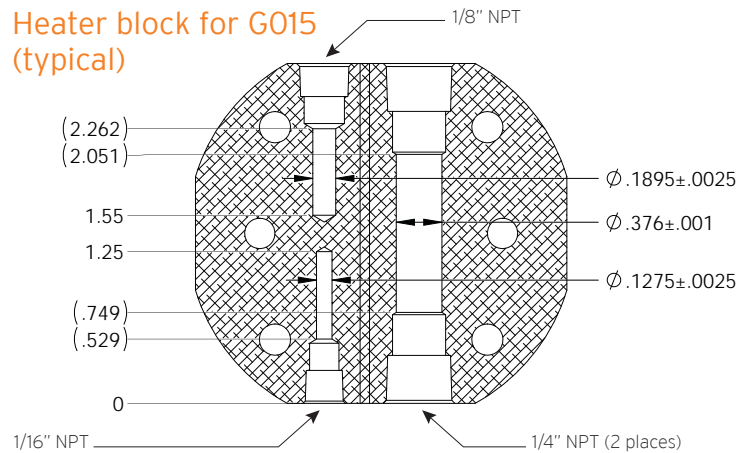

NOTES:

1: HEATER PORT CLEARANCE IS FOR A PROBE WITH 250 WATT/DENSITY MAX AT 400° F

Contact for Repairs & Calibration Services

The G Series is not designed for user repair and all such work should be done at the factory or under the direct supervision of the Max Technical Service Department. Unauthorized repair work may damage the meter and will void the product warranty. Please make note of model and serial numbers on the flow meter before calling the factory. A return goods authorization number will be issued if the flow meter has to be sent back for repair.

Max Machinery, Inc.
33A Healdsburg Ave
Healdsburg, CA 95448

Phone: 707-433-2662
Fax: 707-433-1818
www.maxmachinery.com

Positive Displacement Flow Meters

Gear Type, G Series

Flow Meter Selections

Model #

HS

Max flow range

4 Liters/min	G004
15 Liters/min	G015
45 Liters/min	G045
105 L/min	G105
240 Liters/min	G240

Pressure

6000 psi (420 bar)

Note: G240 limited to 4000 psi (240 bar) if specified with NPT connections

Fluid Connection

NPT	1
SAE	2

Seal Selection

Viton® - FKM	1
Teflon® - PTFE***	3
Perfluoroelastomer - FFKM	5

Options

None	NA
Heat trace option	HT

Transmitter Selections

1 -

Non-standard options

BID Bi-directional cal

1 Transmitter Type

Output Type

A	A	4-20mA output - powered by 24Vdc
A	B	4-20mA output - powered by 12Vdc
A	C	0-10Volt output - powered by 24Vdc
A	D	0-10Volt output - powered by 12Vdc
P	N	5V Pulse/Quad - powered by 5-26Vdc
Q	N	5V Quadrature - powered by 5-26Vdc
P	S	Current Sinking, single phase

Temperature Rating

1	90°C
2	130°C Haz-Loc / 155°C Industrial **
3	225° C - 2 part Industrial †

Electrical Connection

1	Turck® connector
2	Hazardous location*

SIGNAL TYPE

P	Pulse
A	Analog
Q	Quadrature

Calibration

Price includes unidirectional calibration

* See temp chart

** Receiver portion of 2 part transmitters are not rated Ex-Proof, consult factory

*** Teflon not used above 90°C for this high pressure rated product.

† Not available for hazardous location use. (Exceeds 130°C temp. limit.)



Model G045

Limited Warranty



The Seller warrants all equipment manufactured by it to be free from defects in materials and workmanship in normal service for a period of twelve (12) months from the date of shipment. When given prompt notice by the Purchaser, the Seller shall, in complete fulfillment of its liabilities under this warranty, correct by repair or replacement any such defect without charge F.O.B. the Seller's factory, with the following stipulations:

1. Product is not to be returned to Seller without first obtaining a product-evaluation quote number from our Customer Service Department at (707) 433-2662.
2. Seller assumes no liability for charges incurred for repairing, removal or replacement, or for repairs made outside of its factory.
3. Seller reserves the right to inspect products claimed defective under warranty and is the final authority on the validity of the warranty claim. (Actions that void the warranty include, but are not limited to, disassembly of the meter, failure to install recommended filtration or passing incompatible liquids through the meter.)

IT IS EXPRESSLY AGREED THAT THIS WARRANTY OR ANY OTHER WARRANTY STATED OR REFERRED TO ON THE SALES ORDER DOCUMENT IS EXCLUSIVE AND IN LIEU OF ANY OTHER WARRANTY OF MERCHANTABILITY, FITNESS OF PURPOSE, OR ANY OTHER WARRANTY OF QUALITY, EXPRESS OR IMPLIED.