



Max Machinery, Inc.  
an ISO 9001:2008 certified company

## Model G240 Gear Flow Meter (Frequency)

### 250 cc/min to 240 liters/min

#### SPECIFICATIONS

Flow Range	250 cc/min to 240 liters/min
Accuracy (at 30 cP)	± 0.3% of reading over a 100:1 range
Maximum Operating Pressure	275 bar (4000 psi) - NPT fittings 414 bar (6000 psi) - SAE fittings
Displacement	133 cc/rev
Weight	21 kg
Recommended Filtration	30 micron
Port Size(s)	1" NPT or #16 SAE
Fluids	Most non-aqueous, hydrocarbon based fluids



#### MATERIALS OF CONSTRUCTION

Body	Stainless steel, type 303
Gears and Shafts	Stainless steel, type 17-4
Bearings	All ball bearings, 440C stainless steel
Seals	Viton®- standard, Teflon®, Perfluoroelastomer – optional

#### FREQUENCY TRANSMITTER

Output Signal	5 Vdc square wave – Current Sinking, 20mA max.- optional
Output Resolution	Selectable: 1 - 1000 pulses/rev (up to 7 pulses/cc)
Optional	Quadrature square wave, 1 - 500 pulses/revolution/channel
Power Supply Requirements	5 - 26 Vdc, @ 30 mA
Ambient Operational Range	-40°C to 80°C, Single piece – Two piece to 110°C
Metered Liquid Temp Range (based on 20° ambient)	-40°C to 90°C, Standard model -40°C to 155°C, Two piece high temperature model -40°C to 225°C, Two piece, ultra high temperature model
Compliance	CE Certified, Ex-proof version available with ATEX/IECEx II 2 G Ex d IIB Tx Gb as well as UL, cUL certification for Class 1, Division 1, Groups C and D, Tx

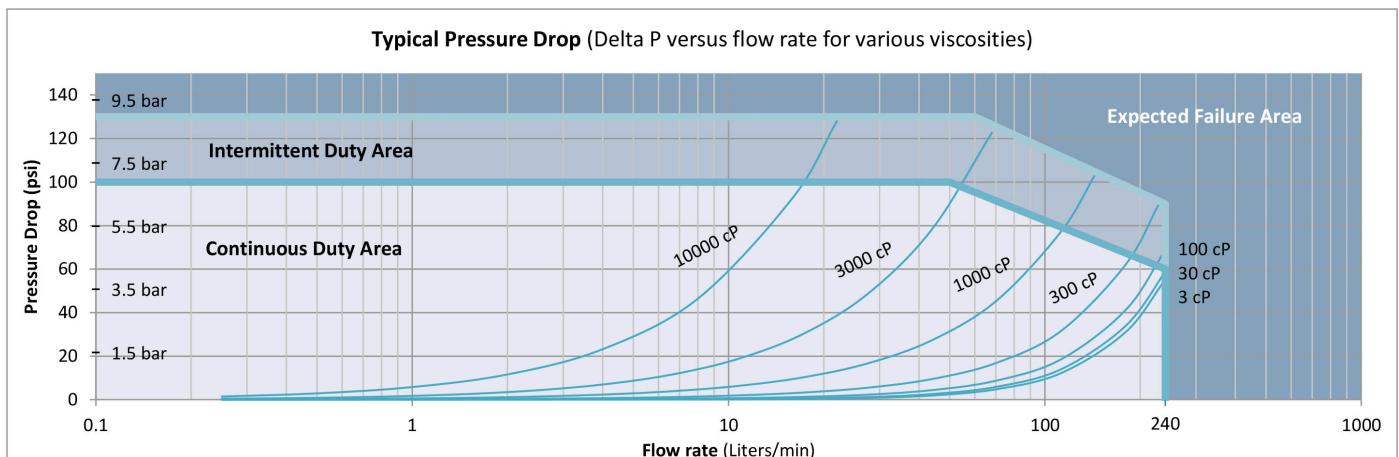

# Model G240 Flow Meter (Frequency)

## CONNECTIVITY/DIMENSIONS

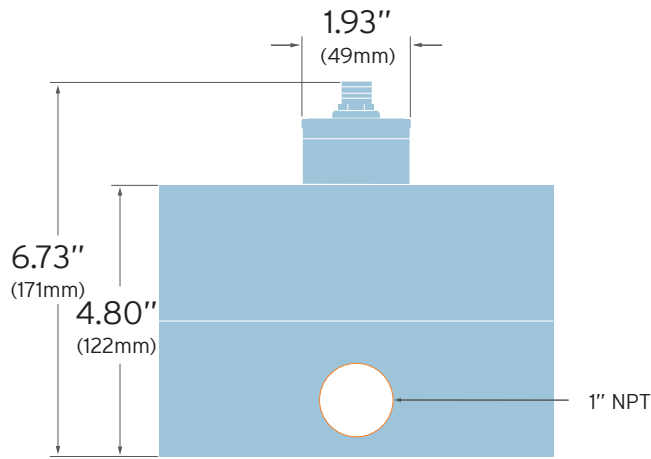

MODEL G240 WITH INDUSTRIAL HOUSING TRANSMITTER

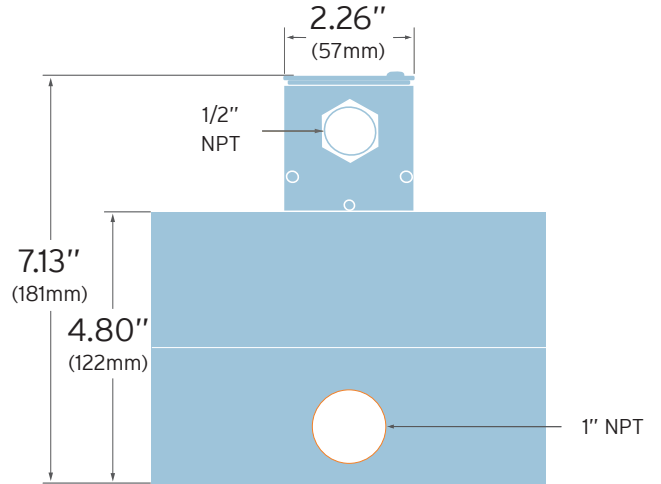

MODEL G240 WITH EX-PROOF HOUSING TRANSMITTER

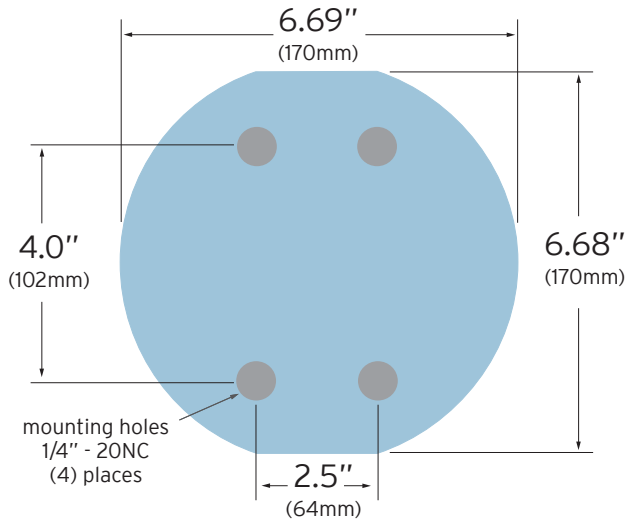

BOTTOM VIEW

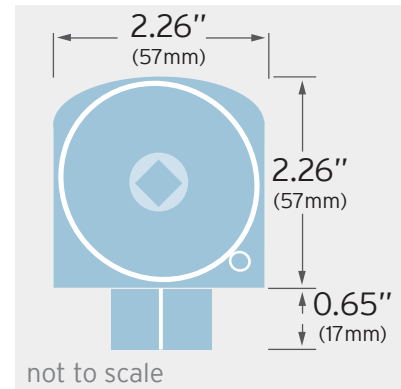

EX-PROOF HOUSING TOP VIEW

### ELECTRICAL CONNECTION - FREQUENCY TRANSMITTERS

	Turck® Connector		
	Pin #	Mating Cable Wire Color	NPT model
Case Ground	3	Blue	Case
Common	4	Black	Com
Power (+5-26 Vdc)	1	Brown	V+
Single Phase:			
Pulse Output	2	White	Ph A
N/A	5	Grey	NC
Quadrature:			
Output Phase A	2	White	Ph A
Output Phase B	5	Grey	Ph B

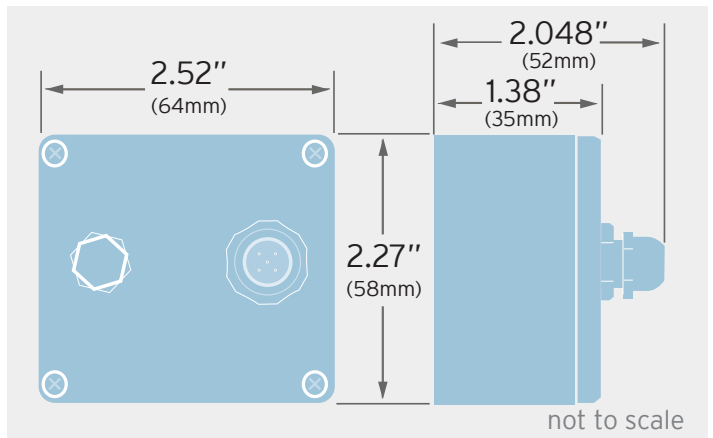

REMOTE PCA ENCLOSURE FOR HIGH TEMPERATURE TRANSMITTERS  
(2 meter interconnect cable, not shown)

