



Max Machinery, Inc.

High Resolution, Linearized Frequency Transmitters

Operational Manual



For Models

295, 296 and G Series Transmitters

Table of Contents



General Description	3
Transmitter Specifications	4
Installation	5
High Temperature Operation	7
Temperature Limits	8
Limited Warranty	9

Custom Instructions for Hazardous Locations/Explosion Proof Housing:

www.maxmachinery.com/content/explosion-proof-installation-instructions

Additional technical documents regarding transmitter performance and advanced operation are available at www.maxmachinery.com. Max Machinery, Inc. reserves the right to make changes to the product in this instruction manual to improve performance, reliability, or manufacturability. Contact Max Machinery Inc. for the latest available specifications and performance data. Although every effort has been made to ensure accuracy of the information in this instruction manual, Max Machinery Inc. assumes no responsibility for inadvertent errors.

General Description

The Max frequency transmitters are designed to work with the entire family of Max Flow Meters to provide extremely precise flow measurement in a cost effective package. Different options for electrical connections and temperature ranges cover a wide range of application environments - from the laboratory to harsh industrial processes.

This latest generation of transmitters use modern sensor technology coupled with advanced signal processing to deliver new levels of performance and reliability. Hall sensors are used to detect the position of a driven magnet inside a Max Flow Meter. Changes in position are tracked by a microprocessor, which generates an output frequency proportional to the flow rate. Advanced signal processing provides both fine angular resolution (0.36 degrees rotation per pulse) and rapid response (output updated every one ms).

These transmitters are typically mated to a mechanical flow meter, configured, and calibrated at the factory as a matched set. This ensures accuracy and allows quick setup in the field. For field installations where the transmitter has not been setup with a meter at the factory, an optional serial interface kit provides full access to all configuration options and parameters.

Transmitter Features

High resolution measurement - Configured output resolution of 1 to 1000 pulses per revolution.
Linearization of up to 16 points to fully describe the flow meter's output curve and achieve the highest system linearity over the meter's entire operating range.

Compensation Algorithm - Compensates for variations in Hall sensor and flow meter characteristics to provide a stable, undamped output frequency that accurately represents the instantaneous flow rate. This feature is factory set when the meter and transmitter are mated together. If the transmitter is changed, the compensation can be performed via a button on the PCA.

Anti-Dither Pulse Buffer - Prevents undesired reverse pulses which can occur at very low flow rates in the presence of vibration or hydraulic noise. If the meter reverses direction and then resumes forward rotation, the pulse count will represent only the total forward flow. Reverse flow exceeding the pulse buffer setting will result in an output frequency proportional to reverse flow rate. The buffer quantity can be set from 1% to 100% of a revolution.



Transmitter Specifications



Supply Voltage	5-26 Vdc	
Supply Current	25-30 mA typical	
Output (5.0 Volt Supply) (TTL and CMOS compatible)	No Load 2.5K Load to Common 2.5K Load to +5 Volts	0.00 / 4.80 Volts 0.00 / 4.60 Volts 0.25 / 4.80 Volts
Short Circuit Current ⁽¹⁾	45 mA	
Output Impedance	100 Ω	
Rise/Fall Time	0.2 μ Sec	
Output Update Rate ⁽²⁾	1 ms	
Min/Max Frequency	0-60 kHz	
Resolution	1 - 1000 pulses/rev, Single Phase 1 - 500 pulses/rev/phase, Quadrature	
Ambient Temperature Range	Transmitter (Storage)-40°C to 85°C (-40°F to 185°F) Transmitter (Operation) ⁽³⁾ -40°C to 80°C (-40°F to 175°F)	
Maximum Temperature, Process Fluid (20°C Ambient, 5V supply)	Standard Model 90°C (195°F) - Models 295 & 296 High Temp Model - Model 296 Ultra-High Temp Model 225°C (435°F) - Models 295 & 296	
Anti-dither Range	50% of a meter revolution - unidirectional - 2% bidirectional. (software selectable from 1-100% of 1 revolution)	
Signal Filtering	Software selectable from 1ms to 250ms time constant	

(1) Continuous Short Circuit is not recommended. The output current should not exceed 10 mA

(2) Events are seen as output transitions 1 ms after they occur

(3) Temperature of metered fluid will affect transmitter temperature, see graph

Installation



Mechanical Installation

1. The transmitter is attached to the flow meter's threaded magnet shield. Hand tighten only. (~ 3 ft-lb)
2. The transmitter lid has four thread paths. To realign the cable, remove the lid and rotate up to 180° and retighten using an alternate starting point. Tighten to compress the O-ring seal.

Removal

1. Remove electrical connections
2. Unscrew transmitter, using a wrench if necessary.

Removal note: The transmitter does not need to be removed from the flow meter for any field servicing or adjustments. Normally, the flow meter and transmitter are shipped back to the factory for calibration or service as a unit. If the transmitter needs to be removed from the flow meter for installation, be sure to retighten the transmitter snugly in order to ensure proper sensor alignment.

Moisture Protection

On all models, the housing is designed as a liquid and vapor-tight enclosure. There are O-ring seals at the lid and possibly also the base of the housing – these need to be fully seated. A properly sealed transmitter will prevent the formation of damaging moisture inside the housing.

Turck connector Model: The connector is sealed to the lid at the factory and is ready for use.

NPT Model: To ensure a moisture-tight seal, apply appropriate sealant to the threads at installation.

Electrical Installation – Wiring

The electrical connector versions are pre-wired inside the transmitter and ready to accept a mating cable (available from the factory). The liquid-tight, NPT models need to be wired during installation as shown in the table below:

Frequency Single Phase	Models 295 & 296	Mating Cable Wire Color	Turck Pin #
Case Ground	Case	Blue	3
Common	Com	Black	4
Power 5-26 Vdc	V+	Brown	1
Pulse Output	Ph A	White	2
N/A	NC	Grey	5

* A current sinking device produces an output pulse which is the opposite of a sourcing device. A positive DC voltage must be applied to the wire running between PhA and your PLC. When the output is triggered, this voltage will be grounded to zero volts. Note: use a 5k ohms resistor to limit the current flow in the signal line.

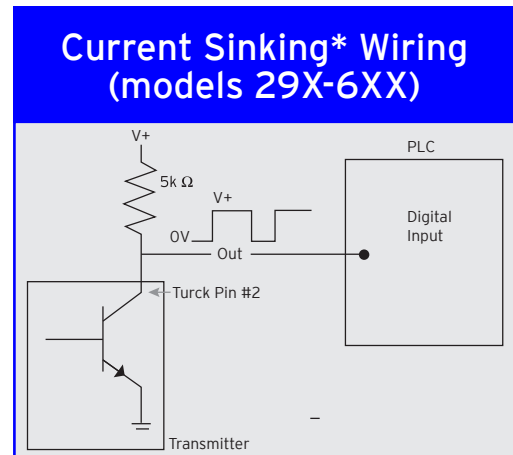

Frequency Quadrature	Models 295 & 296	Mating Cable Wire Color	Turck Pin #
Case Ground	Case	Blue	3
Common	Com	Black	4
Power 5-26 Vdc	V+	Brown	1
Output Phase A	Ph A	White	2
Output Phase B	Ph B	Grey	5

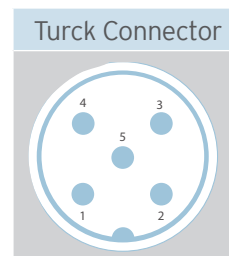



LED Rotation/Output Indicators

All of the microprocessor based transmitters incorporate a LED to indicate that they are producing a pulse output and/or detecting magnet rotation in the meter.

An alternating red/green or blue/green LED indicates that the circuit is detecting a rotating magnet and should provide an output. Additional LED's are present for setup, programming and troubleshooting and are not intended for general use.

Error Codes

Flashes 8x a second to indicate that the magnet is not detected

Note: There are no selections or adjustments to be made on the circuit board. The only method of altering the setup parameters is through the serial interface program. Contact the factory regarding P/N 294-100-050, user interface software.

Field Compensation of transmitter

When a new transmitter is attached to a flow meter, the compensation routine should be performed to optimize the performance of the system. This routine requires a steady flow rate which turns the meter at between 15 and 1000 RPM. For the Model 295 and 296, the sequence is as follows:

1. Stabilize the flow rate
2. Push the compensation button on the PCA
3. The blue/green LED will change to solid blue for 6 to 8 revolutions of the meter
4. A green indicator light indicates a successful update of the compensation, a red indicator light indicates that the previous compensation has been retained.

Shield is only connected at the receiver box end. MUST cover shield with shrink wrap or tape and connect to Brown/Com.

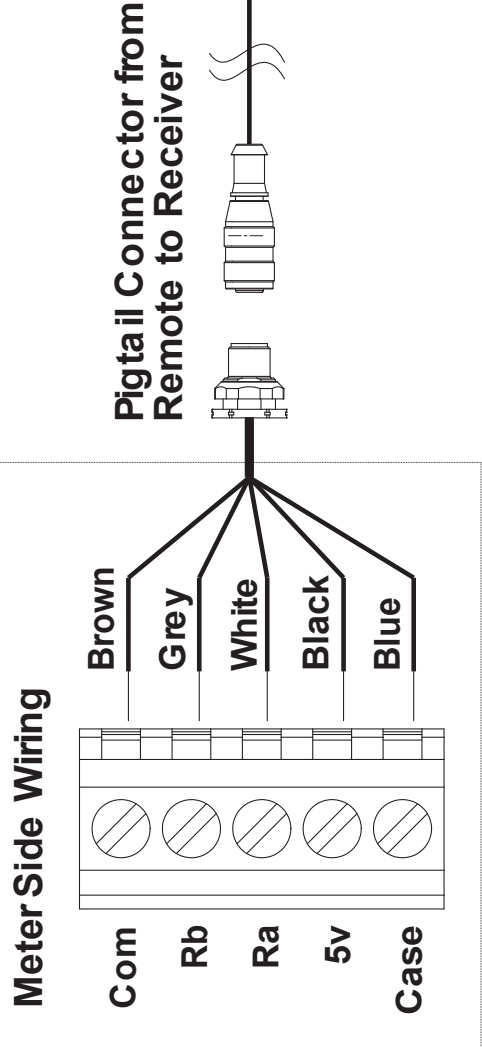
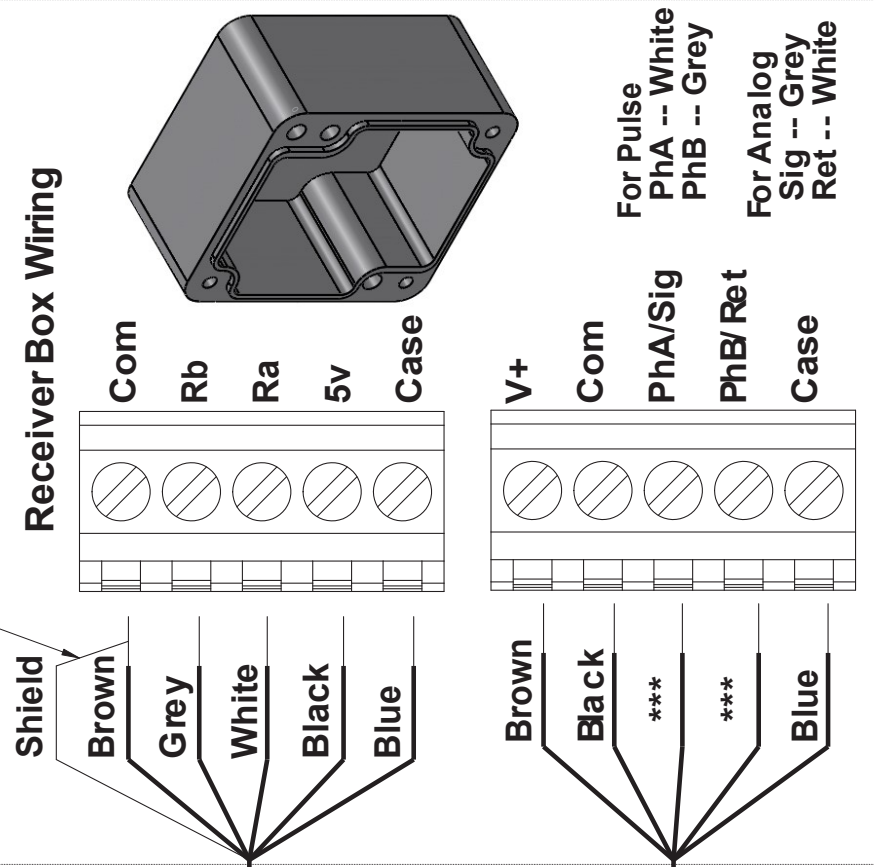

Pigtail Connector from Remote to Receiver



NOTE: For hazardous location installations, customer must supply their own cabling and conduit between the meter side and the receiving box.

The receiving box must be in a SAFEzone!

Use Standard Cable for Connection to Instrumentation

max
bsnyder

MAX MACHINERY
33A HEADSBURG AVE
HEADSBURG, CA 95448

DATE: 8/23/11

DESCRIPTION: Wiring Diagram for Remote 295/296 Xmtrs

REVISION: -1

SCALE: 1:1

SHEET: 1 OF 1

*** COPYRIGHT ***

THIS DOCUMENT IS THE PROPERTY OF MAX MACHINERY. IT IS TO BE USED ONLY FOR THE LIMITED PURPOSES FOR WHICH IT WAS PREPARED. IT IS NOT TO BE REPRODUCED, COPIED, OR TRANSMITTED IN ANY FORM OR BY ANY MEANS, ELECTRONIC OR MECHANICAL, INCLUDING PHOTOCOPYING, RECORDING, OR BY ANY INFORMATION STORAGE AND RETRIEVAL SYSTEM, WITHOUT THE WRITTEN CONSENT OF MAX MACHINERY, INC.

MAX SURFACE FINISH 64

BREAK ALL EDGES TO .005" RADIUS UNLESS OTHERWISE NOTED. TOLERANCE ON THESE DIMENSIONS IS .010

FRAC T ± .164

3RD ANGLE PROJ

ANGULAR ± 1°

High Temperature Operation

Operation Above 65°C (150°F)

The operating limit of the meter/transmitter is a function of both the ambient and the metered fluid temperature, as shown in the following graphs. Although the electronic components are rated to 80°C (175°F), additional heat can be conducted from the flow meter into the transmitter housing requiring a lower ambient temperature limit for high fluid temperatures.

To prolong the life of the transmitter and reduce the risk of component related failures over time, high ambient temperatures >65°C (150°F) should be avoided if possible. It is a good idea to locate the transmitter away from hot spots such as steam pipes, ovens and heaters. When working with elevated fluid temperatures >65°C (150°F), insulating the flow meter is required to reduce heating of the electronics by convection of hot air off of the meter (especially for larger meters). The upper temperature limits shown in the curves rely on ambient convection to remove heat from the transmitter housing, cooling the electronics. For this reason, if operating near the upper temperature limit, the transmitter should not be insulated. At these elevated temperatures, the transmitter will be very hot – exercise appropriate caution.

Temperature Limits

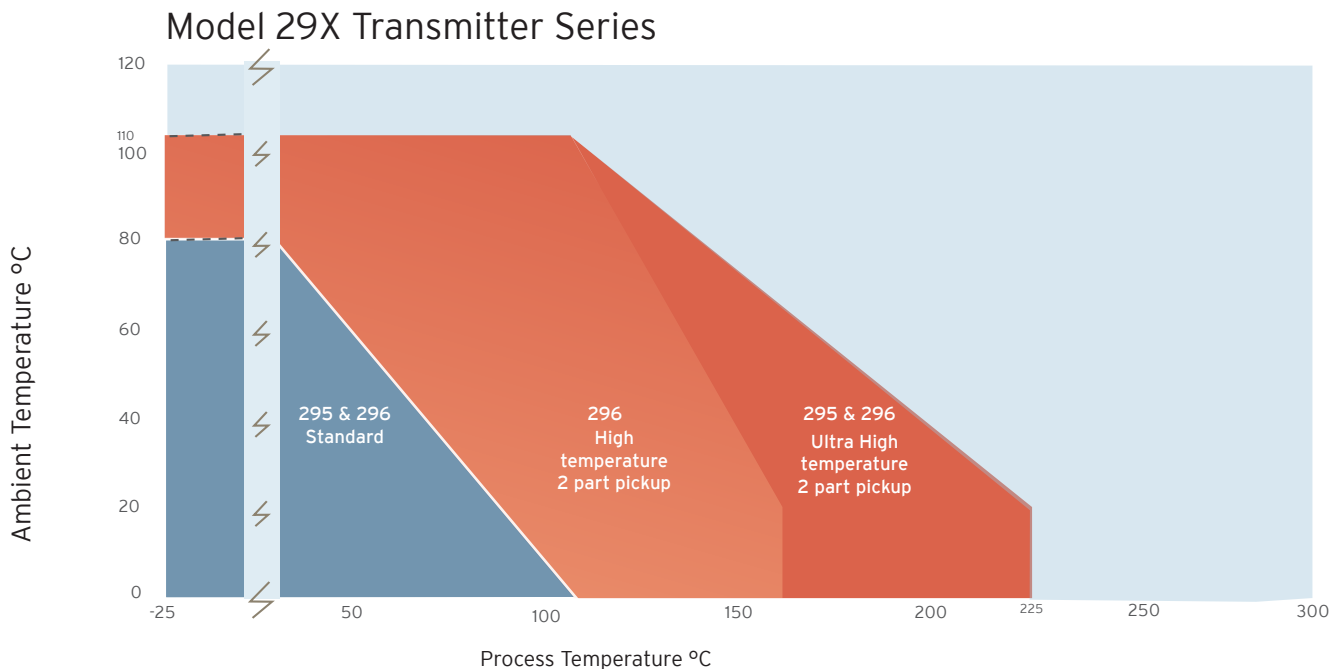

Limited Warranty



The Seller warrants all equipment manufactured by it to be free from defects in materials and workmanship in normal service for a period of twelve (12) months from the date of shipment. When given prompt notice by the Purchaser, the Seller shall, in complete fulfillment of its liabilities under this warranty, correct by repair or replacement any such defect without charge F.O.B. the Seller's factory, with the following stipulations:

1. Product is not to be returned to Seller without first obtaining a product-evaluation quote number from our Customer Service Department at (707) 433-2662.
2. Seller assumes no liability for charges incurred for repairing, removal or replacement, or for repairs made outside of its factory.
3. Seller reserves the right to inspect products claimed defective under warranty and is the final authority on the validity of the warranty claim. (Actions that void the warranty include, but are not limited to, disassembly of the meter, failure to install recommended filtration or passing incompatible liquids through the meter.)

IT IS EXPRESSLY AGREED THAT THIS WARRANTY OR ANY OTHER WARRANTY STATED OR REFERRED TO ON THE SALES ORDER DOCUMENT IS EXCLUSIVE AND IN LIEU OF ANY OTHER WARRANTY OF MERCHANTABILITY, FITNESS OF PURPOSE, OR ANY OTHER WARRANTY OF QUALITY, EXPRESS OR IMPLIED.