

# ***INSTRUCTION MANUAL***

## ***286-300 SERIES TRANSMITTERS***

286-313: Transmitter with Amphenol Connector  
286-323: Transmitter, Weather-Tight, Explosion Proof\*  
286-3x4: Transmitter with Output Level Shifter Option  
286-31x-5xx: Transmitter with Remote PCA

### **TABLE OF CONTENTS**

General Description.....	Pg 2
Specifications .....	Pg 3
Mechanical Installation .....	Pg 4-5
Outputs, Options, and Indicators.....	Pg 6-8
Calibration.....	Pg 9-10
Maximum Transmission Distance.....	Pg 11-12
K-factors.....	Pg 13
Appendix A: Remote Mount Transmitter .....	Pg 14-15
Appendix B: Output Level Shifter Option .....	Pg 16
Schematics:	
286-313-201 RVDT Schematic	
181-000-250 Interconnect Schematic	

\* U.L. Class I, Group C & D  
Class II, Group E, F & G

286-300-350 © 2002, *Max Machinery, Inc.*  
2<sup>nd</sup> Rev: 4/03, added Appendix A and B

*Max Machinery, Inc.* reserves the right to make changes to the product in this instruction manual to improve performance, reliability, or manufacturability. Contact *MMI* for the latest available specifications and performance data.

Although every effort has been made to ensure accuracy of the information contained in this instruction manual, *MMI* assumes no responsibility for inadvertent errors.

### General Description

The 286-3XX Series Transmitter converts the rotary motion of the metering elements inside a *Max* Flow Meter into a frequency proportional to the flow rate. This is accomplished using a differential transformer technique, which puts no torque requirements on the flow measuring elements and enables extremely fast output response rates. A microprocessor measures position changes of the metering elements and generates the corresponding output pulse stream.

When used with the *Max* Series 210 Piston Flow Meters, these transmitters will compensate for cyclical variations in rotational velocity of the metering pistons (inherent in the four piston design) to give a steady output frequency.

The 286-3XX Series circuitry has self-calibration routines that can be initiated with the push of a button. This simplifies matching of flow meter and transmitter in the event that field maintenance is required.

The Model 286 features an antidither output buffer. If the flow reverses (for less than  $\frac{1}{2}$  revolution of the flow meter), and then returns to the forward direction, the transmitter pulse output will represent only the total forward flow. The two-phase output is not buffered; it is an instantaneous indicator of metering element position. The antidithering is a useful feature when the flow stops or is very low, and vibration or hydraulic noise causes the flow metering elements to reverse direction.

The transmitter can be powered from a 4.5V to 30VDC supply. The user can select between two types of outputs: a square wave output or a two-phase output where the frequency of each phase is half that of the square wave output. The user can select from square wave outputs of 24, 50, 100, 200, 300, 500, 600 or 1000 pulses per revolution, or two-phase outputs of 12, 25, 50, 100, 150, 250, 300 or 500 pulses per revolution (on each phase).

# Specifications

## Specifications

<b>Supply Voltage</b> .....	4.5 VDC to 30 VDC	
<b>Supply Current</b> .....	12mA Typical, 20mA Maximum (+ Load)	
<b>Output (5.0V Supply)</b> .....	Hi	Lo
No Load.....	4.80 V	0.04 V
2.5k Load to Common.....	4.60 V	0.04 V
2.5k Load to +5 Volts.....	4.80 V	0.25 V
Short Circuit Current <sup>1</sup> .....	45 mA	
Output Impedance .....	100Ω	
Rise Time .....	0.15 uS (90%)	
Fall Time .....	0.15 uS (90%)	
Maximum Frequency .....	60 kHz	
Minimum Frequency.....	0 Hz	
<b>Maximum Rotor RPM</b> .....	3600 RPM	
<b>Minimum Rotor RPM</b> .....	0 RPM	
<b>Pulse Width Variation</b> (between consecutive rising edges) .....	±15% max	
<b>Output Lag</b> <sup>2</sup> .....	0.25 mS	
<b>Ambient Temperature Limits</b> <sup>3</sup>		
Electronics		
Storage.....	-40°C to 85°C	
Operation.....	-40°C to 80°C	
Stator .....	-40°C to 130°C (265°F)	
<b>Estimated Microprocessor Memory Lifetime</b> <sup>4</sup>		
80°C.....	20 yrs.	
55°C and below .....	>50 yrs.	
<b>Antidither Range</b>		
Pulse Output .....	1/2 Revolution	
Switching of Pin #6.....	1/4 Revolution	

<sup>1</sup> Continuous Short Circuit is not recommended. The sum of output currents during operation should not exceed 30 mA (i.e.: 30 mA on one output or 15 mA on two outputs).

<sup>2</sup> Events are seen as output transitions 0.25 mS after they occur

<sup>3</sup> Temperature of metered fluid will affect transmitter temperature, see pg. 4

<sup>4</sup> See pg. 8 for more information

## Installation

**Mounting:** The Model 286 transmitter screws on and off of the flow meter. Due to the random location of the starting point of the threads, one transmitter will probably not line up with the “in” and “out” ports of the flow meter like another will. The electrical outlet of the transmitter can be rotated clockwise or counter clockwise one turn by loosening the clamping screw. See the Transmitter Diagram (*next page*).

Two flats are provided for installing the transmitter on the flow meter. Care should be taken when installing and removing the transmitter. The wire of the stator is of fine gauge and can be easily damaged.

**Moisture Protection:** The Amphenol and the weather-tight, explosion-proof transmitters both have their circuitry enclosed in a liquid-tight and vapor-tight enclosure. All joints are sealed by welding or O-rings. If a weather tight condition is desired, either the Amphenol or the weather-tight, explosion-proof transmitter will work. To seal the weather-tight transmitter, pipe dope must be used on the liquid-tight conduit. If an explosion proof transmitter is required, a potted seal fitting must be used.

If a transmitter is located outside and is not properly sealed, moisture may form inside the housing. This will cause the circuitry to give an inaccurate output or, in some cases, no output at all. In the long run, this will cause corrosion and failure.

**Temperature Considerations:** High ambient temperatures (> 120°F/ 50°C) should be avoided if possible. It is a good idea to locate the transmitter away from hot spots such as steam pipes, ovens and heaters. The electronics of the 286 Series Transmitters are rated for operation up to 80° C (175° F). Because some heat travels from the flow meter to the transmitter electrical enclosure, the temperature of the electronics is a function of both the ambient and the flow meter temperature. The graph below shows the relation between the maximum ambient transmitter temperature and the fluid temperature through the flow meter.

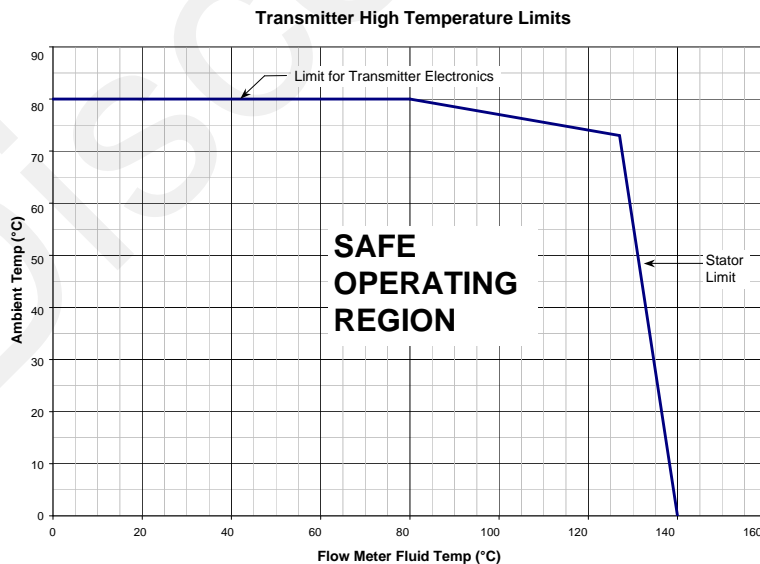

The stator of the 286 transmitters is insulated with an electrical coating that is rated to 130°C which limits the maximum flow meter fluid temperature to about 130°C (265°F).

Transmitter Diagram

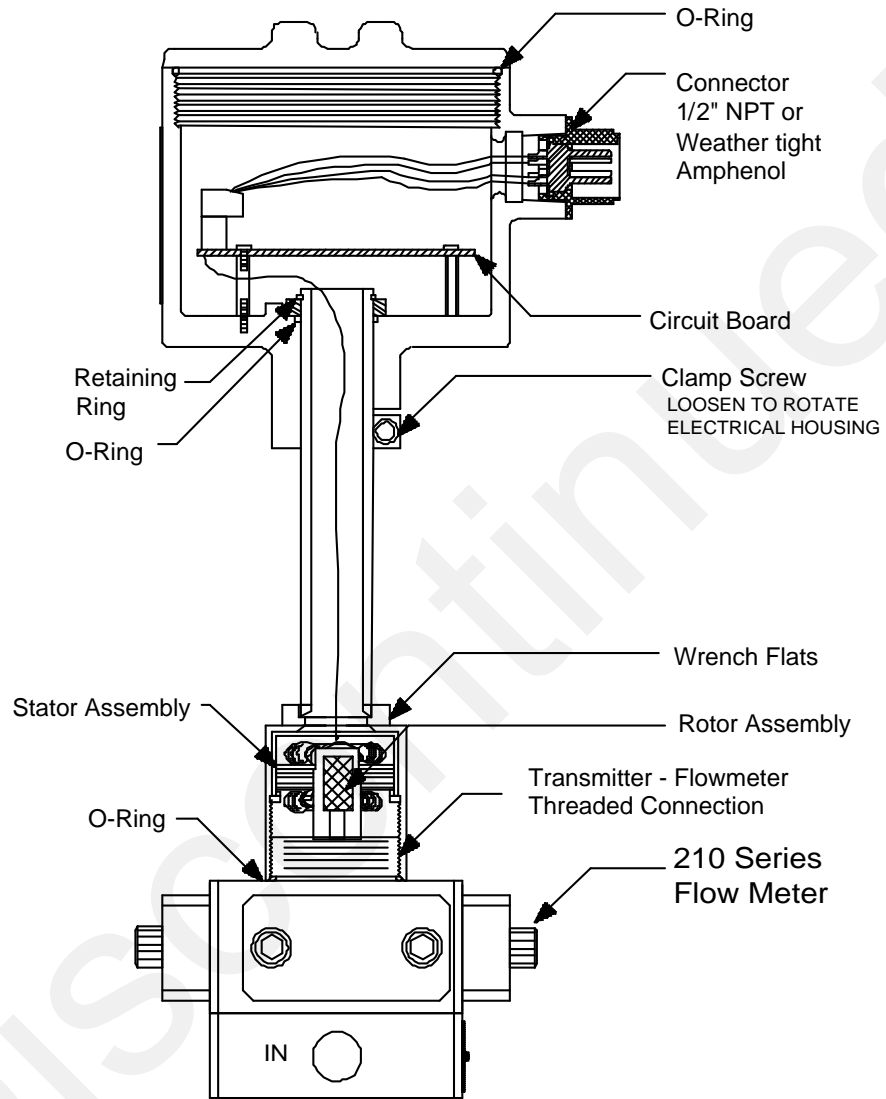

## Outputs, Options and Indicators

### **Connections:**

The interconnect drawing number 181-000-250 at the end of this manual provides detailed information on interfacing to Max signal conditioners and indicators.

### **Output Protection:**

Voltage should not be applied to any output (terminals 4, 5, and 6). If a low voltage,  $\pm 5V$  or less, is accidentally applied to an output, resistors and diodes will protect the circuitry. Higher voltages will destroy the resistors and/or diodes.

### **Grounding:**

S1-1: This switch, (labeled GND) connects Common and Case directly together.

S1-2: This switch, (labeled FILTER) connects Common and Case through two back-to-back 15  $\mu F$  capacitors.

By using either S1-1 or S1-2, the effects of electrical noise on the transmitter can be reduced. If the system is not grounded at the indicator or if the flowmeter is not physically grounded through its plumbing, use S1-1. If the system is grounded at the indicator, use S1-2. This allows electrical noise between the case and the transmitter circuitry to be reduced without causing ground loop problems. To activate either switch, depress the side that is numbered on the switch (and labeled 'GND' or 'FILTER' on the printed circuit board).

### **Meter Selection:**

S4-1: Depress side that corresponds to meter type. The 210 setting is for *Max* Series 210 Piston Flow Meters, and 220/240 is for *Max* Series 220 Gear and 240 Helix meters.

When used with *Max* Series 210 Piston Flow Meters, the Model 286 will compensate for the non-constant rotational velocity of the crankshaft, yielding a steady output frequency at a constant flow rate. If this switch is placed in the wrong position (for either a 210 or 220/240 meter), the output frequency will oscillate  $\pm 20\%$  about its nominal value, four cycles per revolution.

### **Two-Phase or Square Wave Select:**

S4-2: Depress side that corresponds to desired output. '2PH' gives a 2-phase quadrature output with the two phases separated by  $90^\circ$  (Ph A on Terminal 5 and Ph B on Terminal 6). The 'COMB OUT' setting gives a single square wave output that combines the information in the two phases into a single output of double the frequency (Combined Output on Terminal 4, Direction on Terminal 6). If S4-2 is set wrong, an unexpected output signal will result since the same output circuitry is used for the two distinct output options (see chart below).

Terminal Output Signals vs. S4-2 Setting		
Connector Terminal(s)	S4-2 = 'COMB OUT' (combined output)	S4-2 = '2Ph' (2-phase output)
4,5	Pulse Output	Phase A
6	Direction	Phase B

# Outputs, Options & Indicators

## Output Frequency Select:

S3: Rotary switch allows selection of output resolutions of 24 to 1000 pulses per revolution (square wave output), or 12 to 500 pulses per revolution (per phase) if the 2-phase output option is selected. The resolution can be changed while the tachometer is operating, and the new value will take effect immediately. See chart below for resolution at each switch setting.

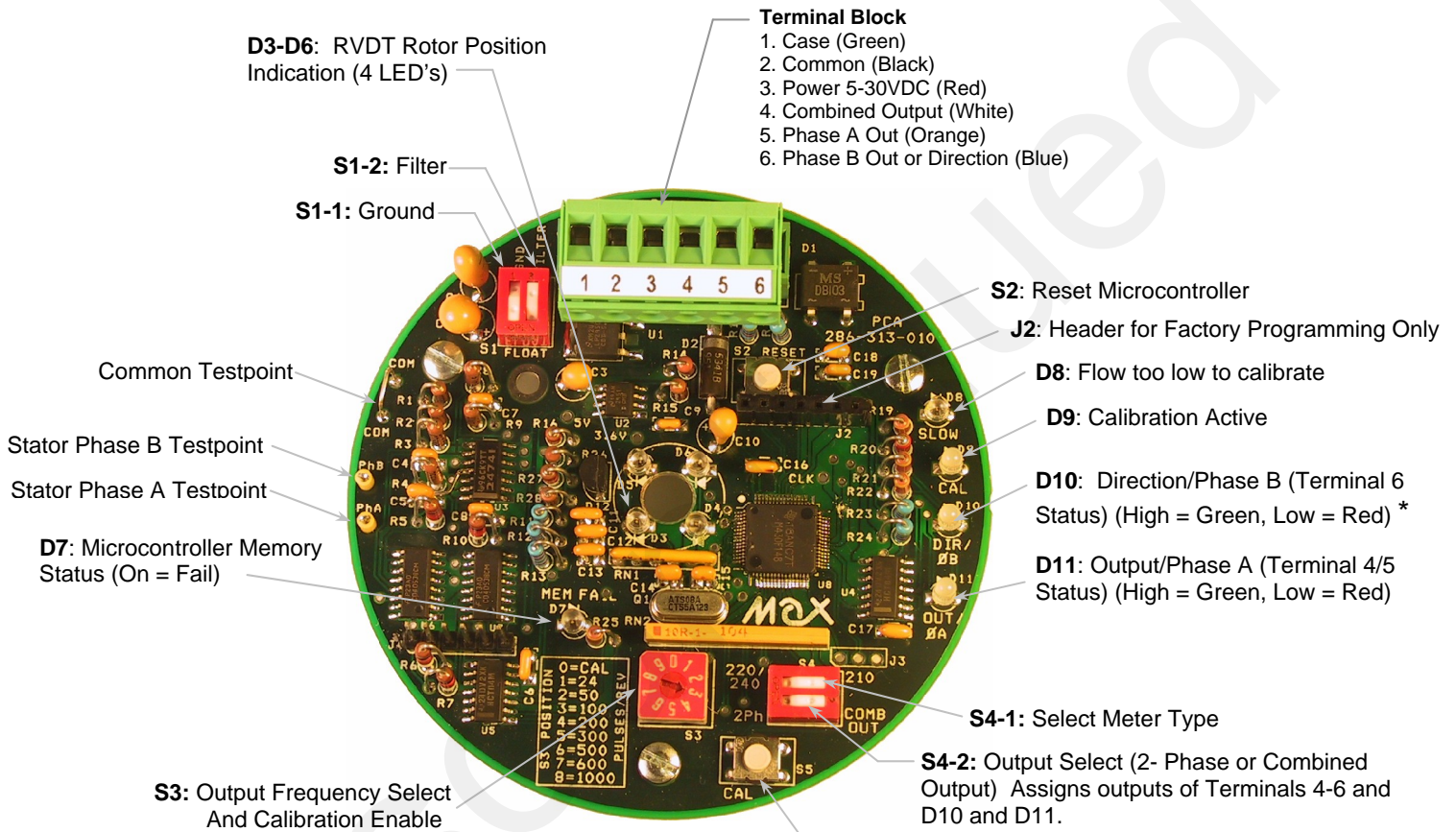

Cycles per Revolution		
S3 Position	2-Phase Output	Combined Output
0	0 (Calibrate)	0 (Calibrate)
1	12	24
2	25	50
3	50	100
4	100	200
5	150	300
6	250	500
7	300	600
8	500	1000
9	*	*

\* Not Specified, Usually same as S3=8

\* Phase A leads Phase B when meter is turning CCW (forward flow on piston and gear style meters, reverse flow on helix meters). Indicated at terminal 6 by a 5 VDC signal and the changing of D10 to green.

### ***Output Indicators:***

D10, D11: These bi-color (red, green) LEDs indicate the status of the outputs. If the 2-phase output mode has been selected, the state of Phase A and Phase B are each shown on the corresponding LEDs ('OUT/ØA' and 'DIR/ØB'). If the combined output mode has been selected, the LED labeled 'OUT/ØA' shows the status of the pulse output channel, and the LED labeled 'DIR/ØB' indicates the direction.

### ***Microprocessor Reset:***

S2: In the event that the tachometer does not appear to be operating correctly, resetting the microprocessor by momentarily depressing S2 may solve the problem. While the reset button is depressed, the 'MEM FAIL' LED will turn on, and if the memory is good, the LED should turn back off when the button is released.

### ***RVDT Rotor Position Indication LED's:***

D3-D6: These LED's provide a graphical representation of the position of the RVDT rotor. This can be a helpful troubleshooting aid when trying to determine if a meter is turning or not. The rotational pattern observed on the LED's corresponds directly to the rotational speed of the RVDT rotor. At high speeds, the LED's will just look like they are blinking; the human eye can no longer discern the direction of motion. At very high speeds the blinking will not even be obvious and they will all appear to be a constant brightness. At these higher speeds, a divide-by-ten feature can be activated by pressing S5 (the 'CAL' button, make sure S3 is not in the 0 position, otherwise the calibration routine will be run!). This only slows down the Rotor Position indication LEDs, the output frequency does not change.

### ***'CAL' LED:***

D9: This LED changes color (red to green or green to red) 4 times per revolution while the microprocessor is performing the calibration routine on the stator coils. When calibration is complete, it will turn off. See Calibration Section for more information on calibration procedures.

### ***'SLOW' LED:***

D8: If a calibration is initiated but the flow rate is too low to give acceptable results, the calibration will be aborted, and this LED will light up red for 10 seconds. See Calibration Section for more information on calibration procedures.

### ***'MEMORY FAIL' LED:***

D7: The microprocessor continually checks the integrity of its program storage memory. If one or more memory values do not read what they are supposed to, this LED will turn on. Two possible causes of memory failure are prolonged operation/storage at temperatures exceeding the ratings and transient voltages applied to inputs and/or outputs that exceed ratings. If the transmitter does not appear to be functioning correctly and this LED is on, the unit should be sent back to the factory for service.



## Calibration

The coils of the Model 286 stator, the printed circuit board, and the flow meter need to be calibrated as one set. When used with any flow meter model, the calibration procedure initiates a routine that determines the offsets needed to balance the output signals from all of the coils. When used with a 210 series piston flow meter, the calibration procedure includes an additional routine that measures the angular position of the stator with respect to the meter. This allows the transmitter to compensate for cyclical variations in rotational velocity of the meter, resulting in a steady output frequency. When S4-1 is in the 210 position (piston meter), the calibration will automatically include both of the routines described above. If S4-1 is in the 220/240 position (Gear or Helix Meter), only the coil balancing routine will be performed.

The recommended flow range for calibration is that which will turn the meter at 20-500 rpm. Lower flow rates (resulting in rotor speeds below 20 RPM) will cause the 'SLOW' LED to come on and the calibration will not take place. Successful calibration will occur at higher flow rates (rotor speeds above 500 RPM) but the results may not be as good as those which would be obtained at a lower flow rate. A flow rate resulting in a flow meter rotor velocity of 100 rpm will give good calibration results.

When doing a calibration on a piston meter, it is critical that the flow rate remains constant (less than 10% variation) for the routine that determines the stator angle to be successful. When a steady flow passes through a four-piston meter, the crankshaft speeds up and slows down 4 times per revolution. The phase of this cyclic speed variation is determined during calibration by finding the position of the 4 speed peaks in a revolution. These speed peak locations are measured for 8 revolutions (32 peaks), then run through an averaging procedure. Once this is done, the tachometer can internally compensate for the speed variations to output a steady frequency under steady flow conditions.

Error can be introduced into this phasing procedure if the system flow rate is pulsating (i.e.: driven by a piston pump). If there are peaks in the flow rate that overshadow the speed peaks due to the 4-piston geometry, the calibration routine will incorrectly determine the phase of the cyclic speed variation and will subsequently apply the compensation out of phase.

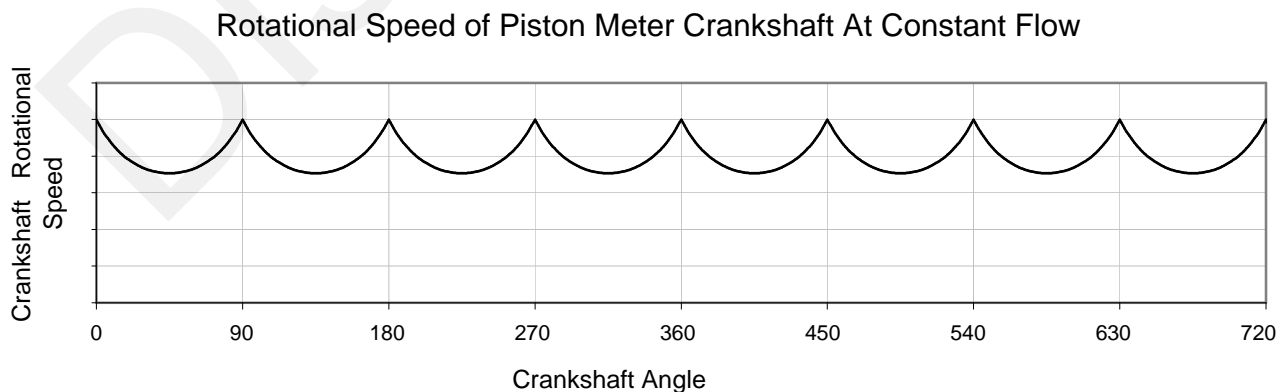

## Calibration

The phase balancing routine that occurs for all types of meters requires 16 revolutions of the meter to reach completion. The 'CAL' LED changes color (red to green or green to red) 4 times per revolution, or 64 blinks for the entire calibration. The angular position determination (phasing) requires 8 revolutions, so the 'CAL' LED will blink an additional 32 times after the 64 phase balancing blinks when calibration is performed on a piston meter. If the flow is stopped partway through a calibration, the blinking will stop and the calibration will not reach completion since it requires a fixed number of meter revolutions. In such a case, a new calibration should be done at a steady flow rate.

### *When to Calibrate*

Calibration should be performed under the following conditions:

1. The Model 286 Tachometer is mated to a flow meter to which it has not been previously calibrated.
2. If the circuit board of the Model 286 is changed.
3. If the connector between the pickup coils and the circuit board is reversed.
4. If it is suspected that the output signal contains more frequency modulation than it should have. (i.e.: Pulse widths vary by more than  $\pm 15\%$ , and variations are not random, but cyclical at 4 times per revolution)

### *Calibration Procedure*

1. Ensure that S4-1 is set correctly (210 for piston meters, 220/240 for gear or helix meters).
2. Set up a steady flow rate through the meter that results in a meter rpm between 20 and 500, ideally somewhere around 100 rpm. The position indication LED's in the center of the circuit board can aid in rpm determination (i.e.: at 100 rpm, each light will blink 10 times in 6 seconds).
3. Rotate S3 to the '0' position to enable calibration.
4. Press the 'CAL' button, S5. If the 'SLOW' LED (D8) comes on, wait 10 seconds for it to go off, increase the flow rate and try pressing the 'CAL' button again.
5. Wait for the 'CAL' LED (D9) to stop blinking and turn back off. While the calibration is active, the position indication LED's in the center of the board will pause. As soon as the calibration is complete, they will resume activity.
6. The calibration is now complete. Return S3 to the appropriate setting to get the desired number of output pulses per revolution.

# Maximum Transmission Distance

## Maximum Transmission Distance

The graph below indicates typical conductor capacitance loads versus cable length for several types of cable. For instance, 1000 feet of 7 conductor #18 gauge stranded wire will put a 0.04  $\mu\text{F}$  capacitive load on the output of the 286-3XX Series Transmitters.



## Maximum Transmission Distance

### Maximum Transmission Distance (continued)

The graph below shows the relationship between output capacitance loading and rise and fall time for the Model 286-3XX output signal. For instance, with 0.04 $\mu$ F load capacitance (1000 ft. shielded cable typ.) the rise/fall time is 10  $\mu$ s. Consequently, the absolute maximum frequency the Model 286 could transmit would be 50 kHz (frequency = 1/time, where time includes the rise and fall times for one cycle). See following page for maximum frequencies possible with different flow meters.

#### **286-313 Output Rise and Fall Time vs. Load Capacitance**

(rise and fall time measured between 10% and 90% of full output swing)

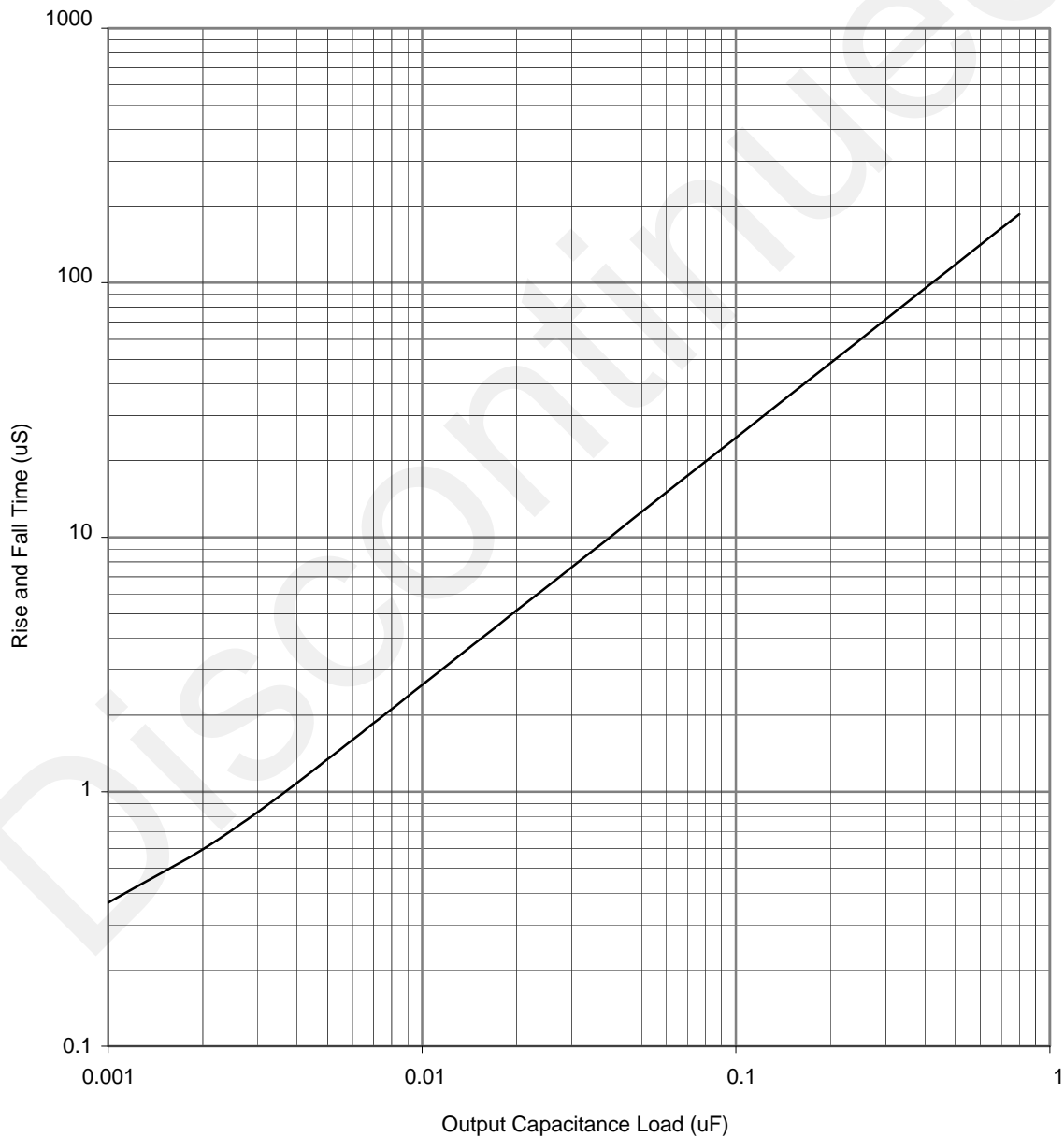

## K-Factors

### K-Factors

K-factors represent the number of pulses the transmitter outputs per unit volume of fluid passing through the flow meter. This number is dependent on the flow meter and the transmitter resolution setting (switch S3). Max Machinery indicators can be adjusted to display the desired units (ccs, lbs, gallons, quarts, etc.) by using the K-factor.

Flow meters are multi-point calibrated at the factory. The K-factor varies slightly with flow rate. A graph of this K-factor is provided for each customer. The values shown below are typical. If the output resolution setting is changed (via S3), the K-factors will scale proportionally:

$$\text{New K-factor} = \text{Existing K-factor} * \frac{\text{New Resolution}}{\text{Existing Resolution}}$$

<b>286-3xx K-Factor Ranges (pulses/cc) with various Max flow meters*</b>					
<b>Model</b>	<b>Combined Output K-factor Range (pulses/cc)</b>		<b>Maximum Rate (liters/min)</b>	<b>Maximum Output Frequency Range (Hz)**</b>	
	<b>Min (@24 pulses/rev)</b>	<b>Max (@1000 pulses/rev)</b>		<b>Min (@24 pulses/rev)</b>	<b>Max (@1000 pulses/rev)</b>
213	27.6	1150.0	1.8	828	34,500
214	2.28	95	10	380	15,870
215	0.504	21.0	40	336	14,000
216	0.142	5.9	100	237	9,870
220	2.28	95.0	3	114	4,760
221	1.02	42.5	15	255	10,630
222	0.506	21.1	38	320	13,350
241	0.386	16.1	190	1,220	50,900
242	0.132	5.50	540	1,190	49,520
243	0.0417	1.74	1400	973	40,500
244	0.0139	0.579	2800	649	27,040
245	0.00396	0.165	5600	370	15,400

\*typical values; may vary by up to 5% on specific flow meters.

\*\*Maximum Count Speed of Max Machinery Indicators:

Model 120 <= 7500 Hz

Model 121 <= 20,000 Hz

If the frequency output at the application's maximum flow rate exceeds the indicator's count speed, then the transmitter resolution setting (S3) will need to be adjusted to proportionally reduce the meter/transmitter's K-Factor.

**286-313-500 Remote Mount Transmitter (Aluminum Housing)**

**286-313-525 Remote Mount Transmitter (Polycarbonate Housing)**

**286-314-500 Remote Mount Transmitter with Output Level Shifter (Aluminum Housing)**

**286-314-525 Remote Mount Transmitter with Output Level Shifter (Polycarbonate Housing)**

**General**

The 286-313-500 and 286-313-525 Remote Mount Transmitters allow the transmitter circuitry to be located separately from the flowmeter and RVDT stator. This may be desirable when a smaller flowmeter package is required, when the flowmeter is subjected to high ambient temperatures (ie: environmental chamber), or for any number of other reasons. Both the remote circuit board housing and the stator housing are fully sealed. The functionality of the remote transmitter is identical to the standard transmitter. There are some differences in appearance and installation due to the different housing and extra connections to the remote stator cable: these are addressed in the information below.

**Mounting**

The cylindrical aluminum stator housing mounts on the flow meter. Care should be taken when installing and removing the stator housing. The wire of the stator is of fine gauge and can be easily damaged. Two wrench flats are provided for installing and removing. The stator housing only needs to be tightened with enough torque to compress the O-ring and prevent unscrewing due to mechanical vibrations and cable forces. 10-15 ft-lbs. of torque is sufficient. **DO NOT OVERTIGHTEN!**

The sealed aluminum or polycarbonate NEMA 4 box containing the circuit board has mounting holes in the four corners that are accessed by removing the cover. The polycarbonate box has 0.175" dia. holes with space for a 0.265" or smaller head. The aluminum box has 0.185" holes with space for 0.300" or smaller head. An 8-32 socket head cap screw works well for both.

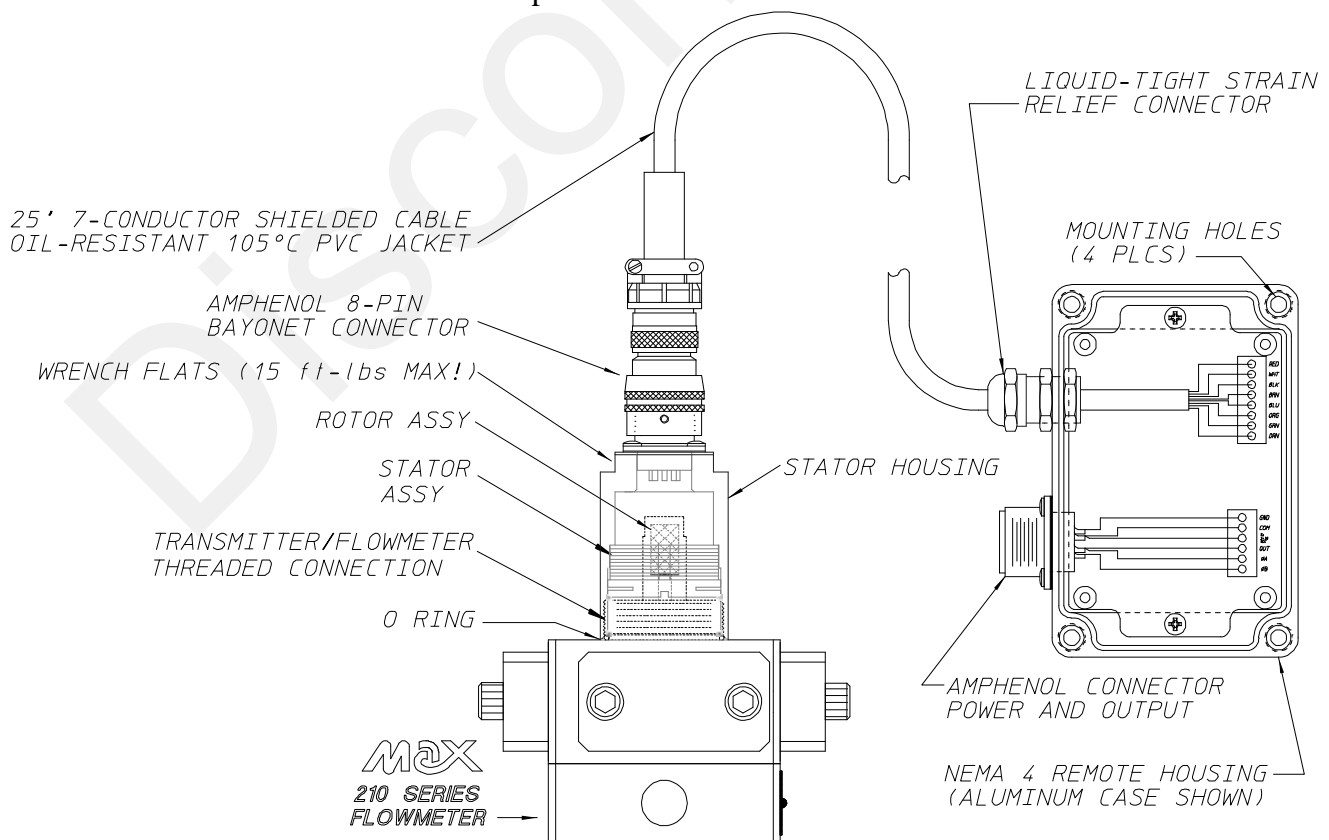

## Temperature Considerations

Continuous exposure of the stator housing and the circuitry to high ambient temperatures should be avoided if possible. It is a good idea to locate both of these components away from hot spots such as steam pipes, ovens, and heaters. The circuitry in the remote enclosure is rated for operation up to 80°C, so this is the limit on the ambient air temperature at the enclosure. At the flowmeter, the metered fluid temperature should not exceed 130° C (265° F) (stator insulation limitation) and the ambient temperature should not exceed 105° C (220° F) (PVC cable jacket limitation).

## Outputs, Options, Indicators

See pages 6-8 of the manual for detailed explanations of the transmitter's outputs, options, and indicators. The diagram below points out the location of the features on the printed circuit board.

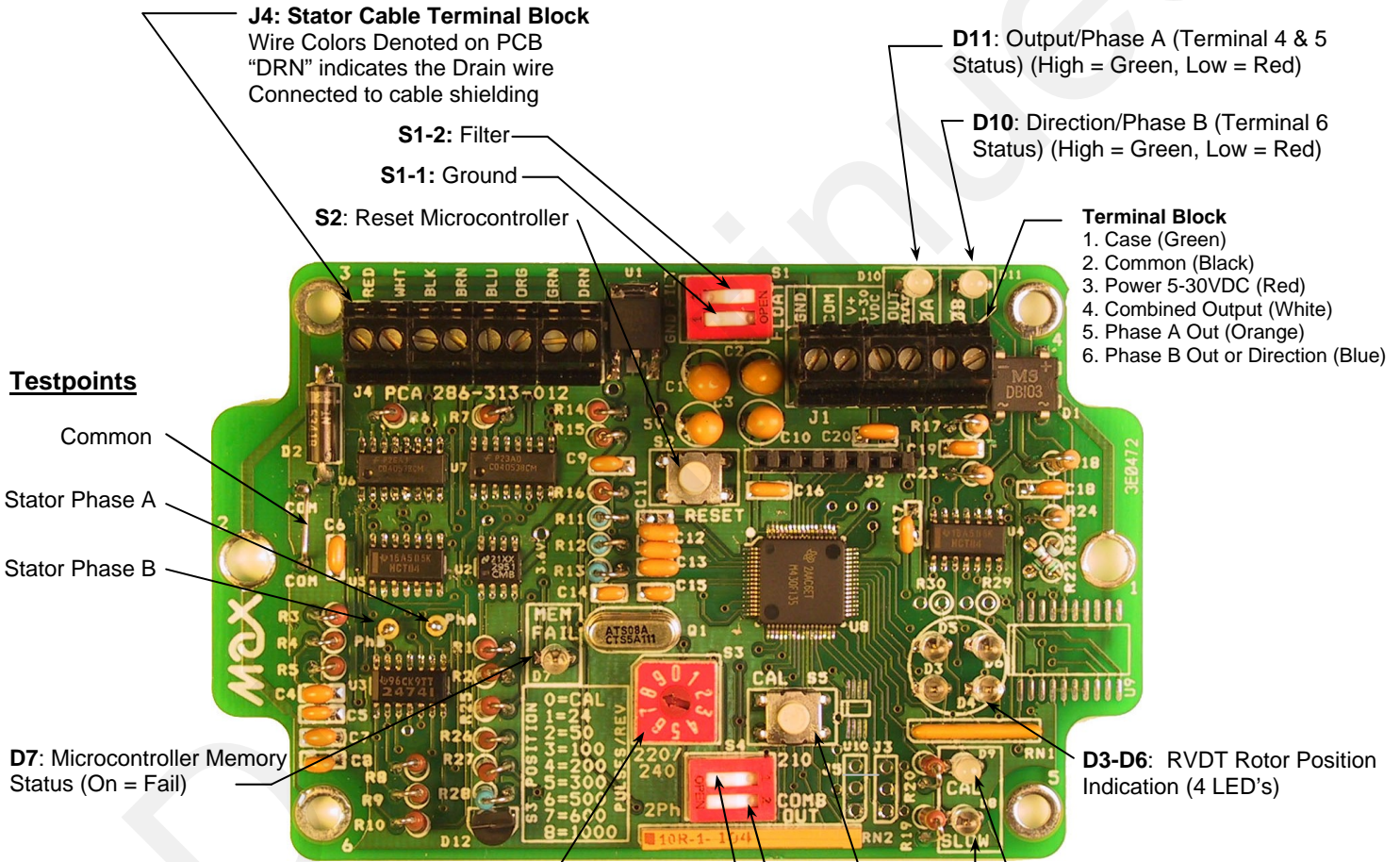

### Testpoints

- Common
- Stator Phase A
- Stator Phase B

D7: Microcontroller Memory Status (On = Fail)

Cycles per Revolution		
S3 Position	2-Phase Output	Combined Output
0	0 (Calibrate)	0 (Calibrate)
1	12	24
2	25	50
3	50	100
4	100	200
5	150	300
6	250	500
7	300	600
8	500	1000
9	*	*

\* Not Specified, Usually same as S3=8

S3: Output Frequency Select And Calibration Enable

S4-1: Select Meter Type

S4-2: Output Select (2- Phase or Combined Output)

S5: Calibrate Stator Offsets (and Angle). Need S3 in position 0 to start Calibration.

## Appendix B: Output Level Shifter Option

**286-314: Transmitter with Amphenol Connector, Level Shifter Option**

**286-324: Transmitter, Weather-Tight, Explosion Proof, Level Shifter Option**

**286-314-500: Remote Transmitter (Aluminum Housing), Level Shifter Option**

**286-314-525: Remote Transmitter (Polycarbonate Housing), Level Shifter Option**

### General

Both the standard and remote transmitter circuit boards have the capability for additional circuitry that gives output voltage levels equivalent to the power supply voltage. For example, if the transmitter is powered with +12 Volts the output will be a 12V square wave. The circuit board used in the level shifter version is identical to the standard circuit board, with the exception of some additional components (R29,R30, and U9) and some that are absent (R23, R24, and D1). The output specifications, some different than those on pg. 3 due to the level shifter, are listed below. All other specifications from pg. 3 not reprinted here remain unchanged.

### Output Level Shifter Specifications

<b>Supply Voltage</b> .....	4.5 VDC to 30 VDC	
<b>Supply Current</b> .....	38mA Typical, 32-43 mA Range (+ Load)	
<b>Output (12.0V Supply)</b> .....		Hi      Lo
No Load.....	12.0 V	0.1 V
2.5k Load to Common.....	11.0 V	0.1 V
2.5k Load to +12 Volts.....	12.0 V	1.0 V
Short Circuit Current <sup>5</sup> .....	120 mA	
Output Impedance .....	100Ω	
Rise Time .....	0.8 uS (90%)	
Fall Time .....	1.0 uS (90%)	
Maximum Frequency .....	60 kHz	
Minimum Frequency .....	0 Hz	

<sup>5</sup> Continuous Short Circuit is not recommended. The output current should not exceed 30 mA per output.