

INSTRUCTION MANUAL

284-512 SERIES

TRANSMITTER

TABLE OF CONTENTS

General Description	Pg 1
Specifications	Pg 2
Installation	Pg 3
Temperature Limits	Pg 5
Signal Transmission Data	Pg 5
Temperature Limit Graphs	Pg 6
Signal Transmission Graphs	Pg 7
K-Factor	Pg 8
Photo Disk Assembly	Pg 9
General Flow Metering Considerations	Pg 10

All schematics are available by contacting MMI Technical Service:

286-700-010

284-510-200

181-000-250

284-512-350 © 1990 (Rev 6/97) Max Machinery, Inc.

Max Machinery, Inc. reserves the right to make changes to the product in this Instruction Manual to improve performance, reliability, or manufacturability. Consequently, contact *MMI* for the latest available specifications and performance data.

Although every effort has been made to ensure accuracy of the information contained in this Instruction Manual, *MMI* assumes no responsibility for inadvertent errors.

General Description

General Description

The 284-512 transmitter is a photo optic device which converts the rotary motion of a typical Max flow meter into an electrical signal whose frequency is proportional to the flow meter RPM. It has two output formats: a square wave of 100 cycles per revolution and a two phase output of 50 cycles per revolution. The single phase output has an antidither feature, which makes it useful for low flow zero velocity applications which may involve momentary reverse flows. A memory circuit will hold up to 128 pulses of negative flow, outputting only the net forward flow. The two phase output is useful for bi-directional applications. Both outputs are CMOS and TTL compatible and are generally able to drive at least 1000 feet of shielded cable.

The 284-512 can operate from a voltage source of 4.5 volts to 30 volts. A wide range on board regulator protects the circuitry from transient supply noise. No adjustments are required for different supply voltages.

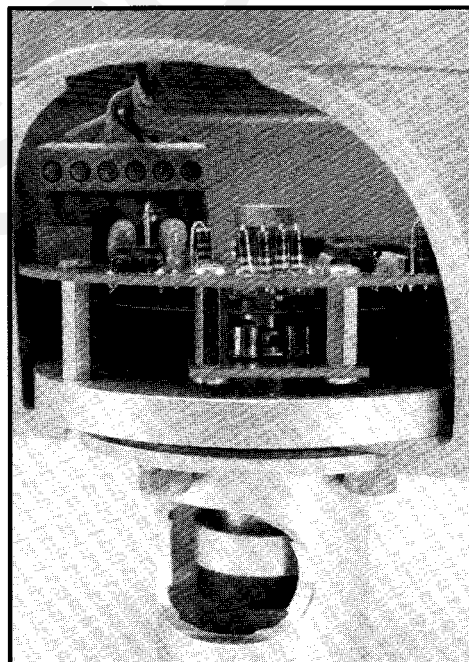
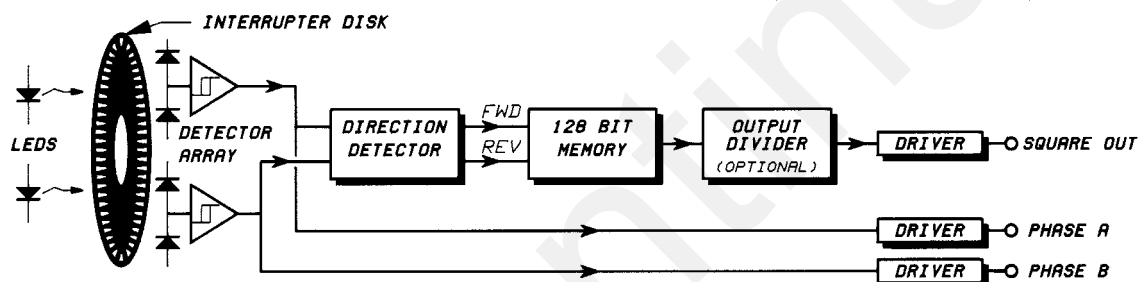

Specifications

Specifications

Supply Voltage	4.5V to 30V DC	
Supply Current	15mA / maximum	
Output Impedance	Less Than 500 Ohms	
Output Voltage	High	Low
No Load	5.0V	0.0V
2.5K Load to Common	4.5V	0.0V
2.5K Load to +5V	5.0V	0.3V
Output Short Circuit Current*	13.75mA Typical	
Rise Time (2.5K Load)	0.7 μ s (90%)	
Fall Time (2.5K Load)	0.4 μ s (90%)	
Output Frequency		
Maximum	6000 Hz	
Minimum	0.0 Hz	
Antidither Range		
(Single Phase Only)	128 cycles	
	1.28 revolutions	
Disk RPM		
Maximum RPM	3600 RPM	
Minimum RPM	0.0	
Temperature Limits		
Storage	-65°C to 80°C	
Operating	-15°C to 65°C	

(The temperature of the material flowing through the flow meter will typically affect the operating temperature of the transmitter, see page 7).

* Sourcing. The 5V sink current is 32mA. Continuous short circuit is not recommended.

TYPICAL 204 K-FACTORS WITH MAX FLOWMETERS

MODEL	SQUARE WAVE OUTPUT	MAXIMUM RATE	MAXIMUM OUTPUT
213	115 PULSES/CC	1800 CC/MIN	3450 Hz
214	9.5 PULSES/CC	10,000 CC/MIN	1583 Hz
215	2100 PULSES/L	40 L/MIN	1400 Hz
216	590 PULSES/L	100 L/MIN	983 Hz
221	4260 PULSES/L	58 L/MIN	4118 Hz
222	2110 PULSES/L	78 L/MIN	2743 Hz
241	1610 PULSES/L	190 L/MIN	5098 Hz
242	549 PULSES/L	540 L/MIN	4941 Hz
243	174 PULSES/L	1400 L/MIN	4060 Hz
244	58.8 PULSES/L	3500 L/MIN	3430 Hz
245	16.5 PULSES/L	8000 L/MIN	2200 Hz

Installation

Installation

Environment: The electrical circuitry of the weather-tight, explosion-proof transmitter is enclosed in a liquid and vapor tight enclosure. All joints are sealed by welding or by "O"-rings. If this sealed condition is to be maintained, the conduit connection to the enclosure should be made liquid and vapor tight by using pipe dope or a potting fitting. If a transmitter is located outside and this precaution is not taken, moisture may form inside the housing.

This will cause the circuitry to give an inaccurate output or possibly no output at all. In the long run it will cause corrosion and failure. The amphenol connector versions of the 284 offer moderate protection from moisture and dust, but are not totally sealed.

The transmitter may be rotated by loosening the screws under the housing (see drawing on Page 5).

Connections: The facing page shows the terminals and their functions. When connecting wires to the screw terminal versions, make sure the lead wires do not rub on the arbor. This arbor rotates and rubbing wires will affect accuracy and may eventually cause a short circuit.

Grounding: Two dip switches are provided. The ground switch, when activated, connects the circuit common to the case terminal. The Filter switch, when activated, connects the circuit common to the case via two back to back capacitors. These two switches facilitate system grounding procedures which will reduce electrical noise problems.

It is advisable to have the common of any system physically grounded at one point only. If your system is grounded at the receiving end then you may not want to ground the common at the transmitter end. In this case, it is advantageous to connect the circuit common to case via the capacitors (filter). This will give some extra immunity to electrical noise.

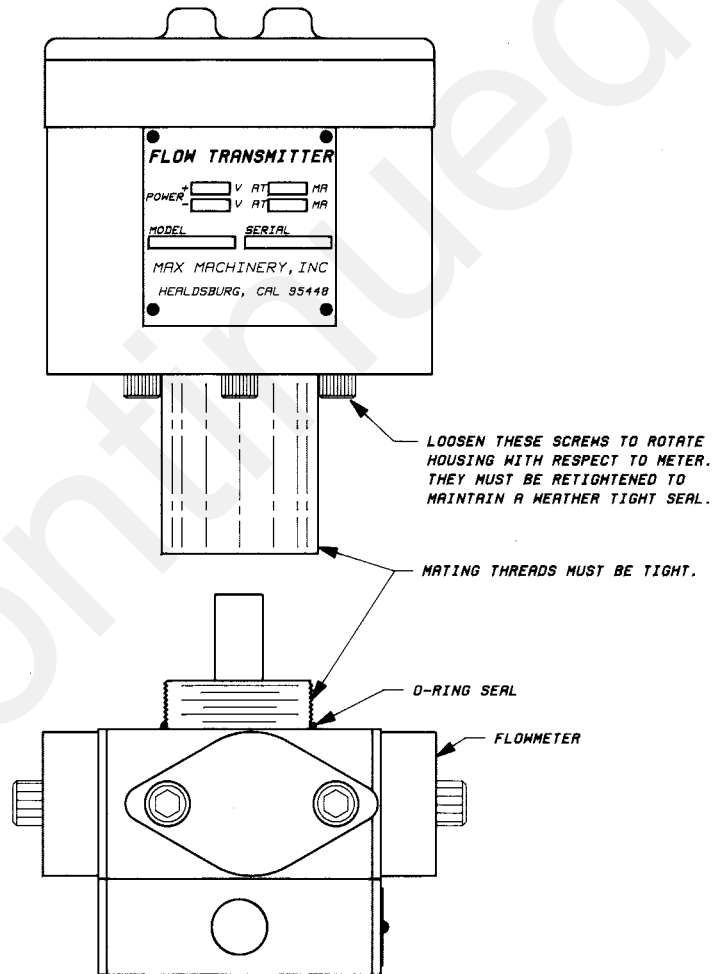

Installation

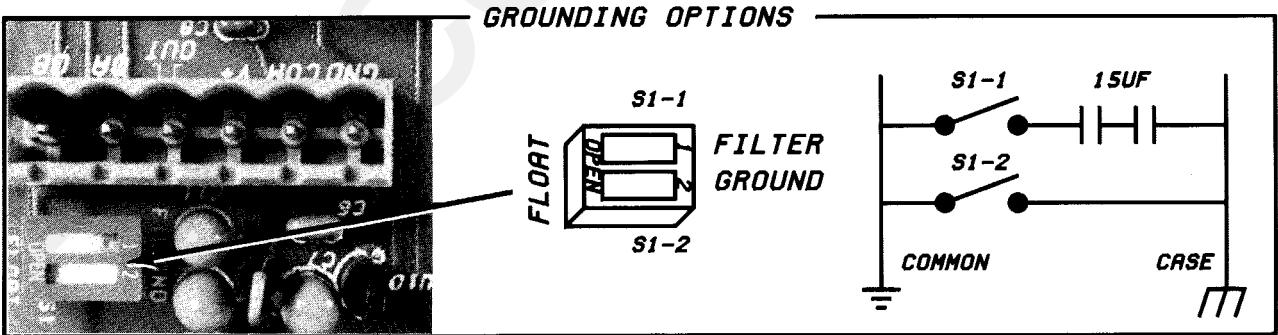
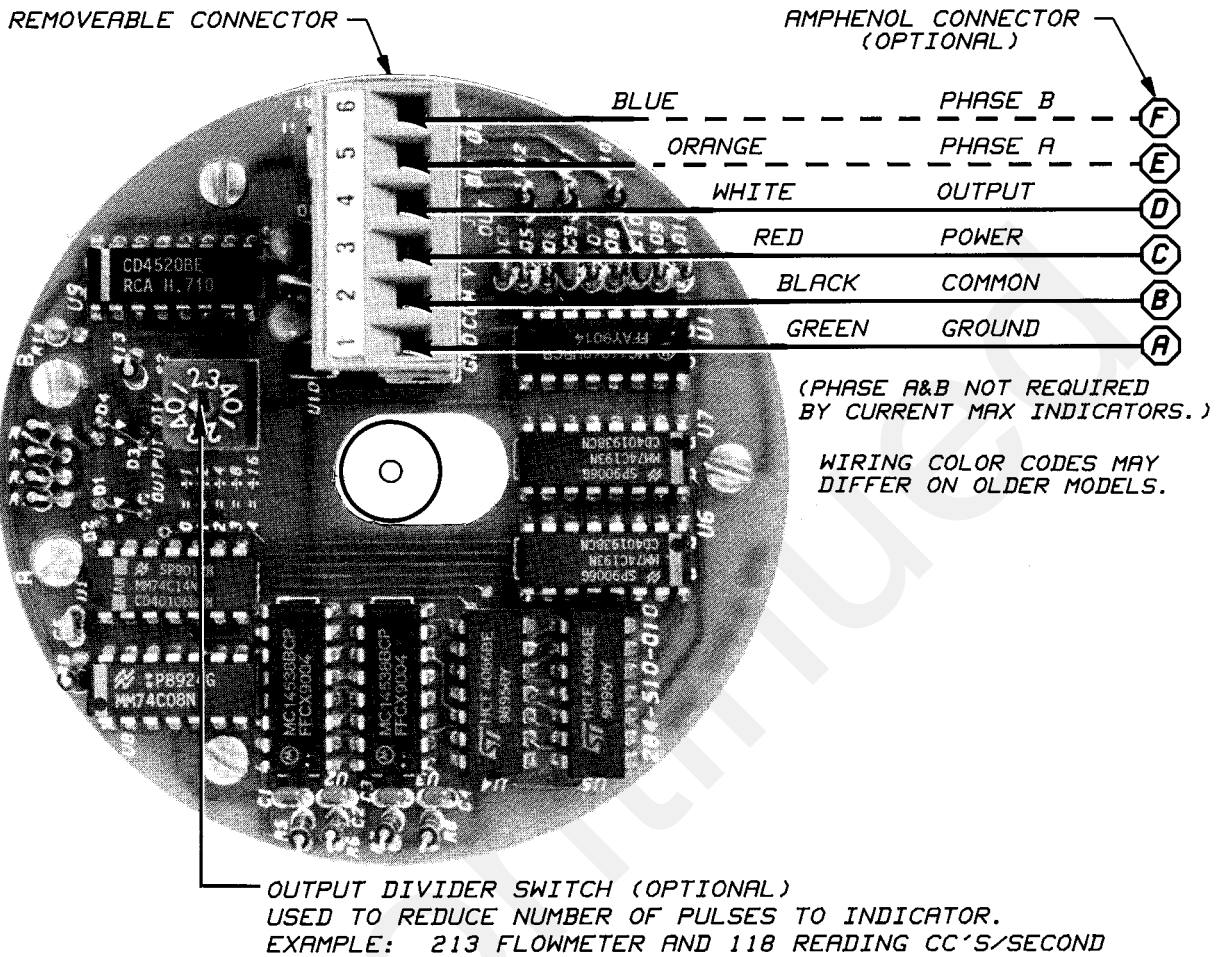

AMPHENOL PINOUT (OPTIONAL)

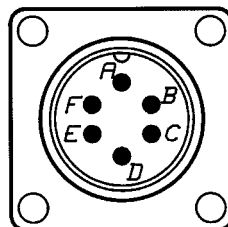

- A=GROUND
- B=COMMON
- C=4.5 TO 30VDC
- D=SQUARE WAVE OUTPUT
- E=PHASE A OUTPUT
- F=PHASE B OUTPUT

Temperature Limits

Temperature Limits

The electronic circuit of the 284 uses components which are intended to operate within the range of -15° to $+65^{\circ}\text{C}$ (5° to 145°F). They will probably operate satisfactorily for brief periods from -50° to $+85^{\circ}\text{C}$, although this is not recommended.

The 284 is thermally connected to the flow meter body. For this reason, the temperature of the 284 will be a function of ambient temperature and the flow meter temperature. The limit of these two temperatures is interrelated, which is shown in Figures 6 and 7. Figure 6 is for the 284 in a vertical position; Figure 7 is for the 284 in a horizontal position.

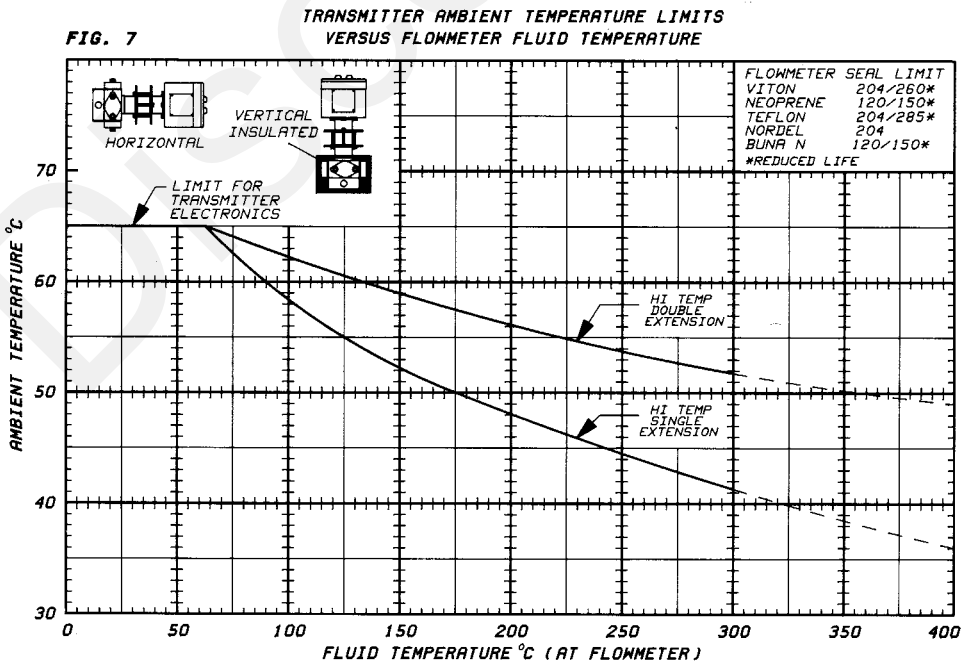
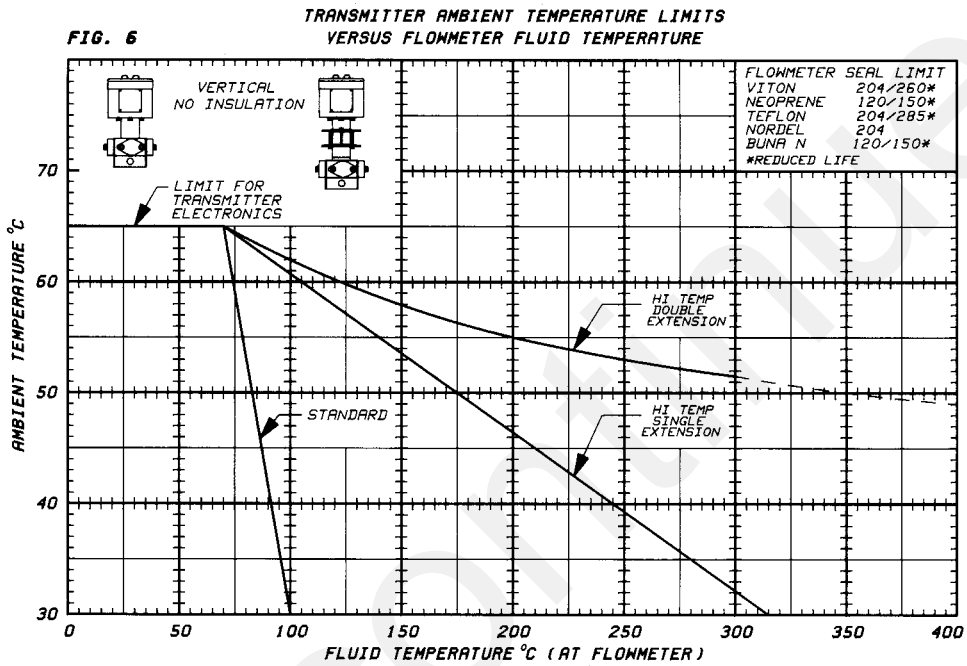

Signal Transmission Data

Signal Transmission Data

Figure 8 is a graph which indicates typical conductor capacitance loads versus cable length for several types of cable. For instance, 1000 ft. of 7 conductor # 18 gauge stranded wire will put a 0.04 μf capacitive load on the output of the 284-512 series transmitters.

Figure 9 provides the relationship between output capacitance loading and rise and fall time for the 284-512 output signal. For instance, at 0.04 μf , the rise time of the 284 is about 18 μsec , the fall time is about 8.5 μsec .

Consequently, the absolute maximum frequency the 284 could transmit would be 26.5 $\mu\text{sec} = 37,736\text{ Hz}$ (frequency = $1/\text{time}$). This frequency is well above what any flow meter will develop.

Generally, the 284-512 Series transmitters will drive 1000 feet or more of cable with no problem.

FIG. 8

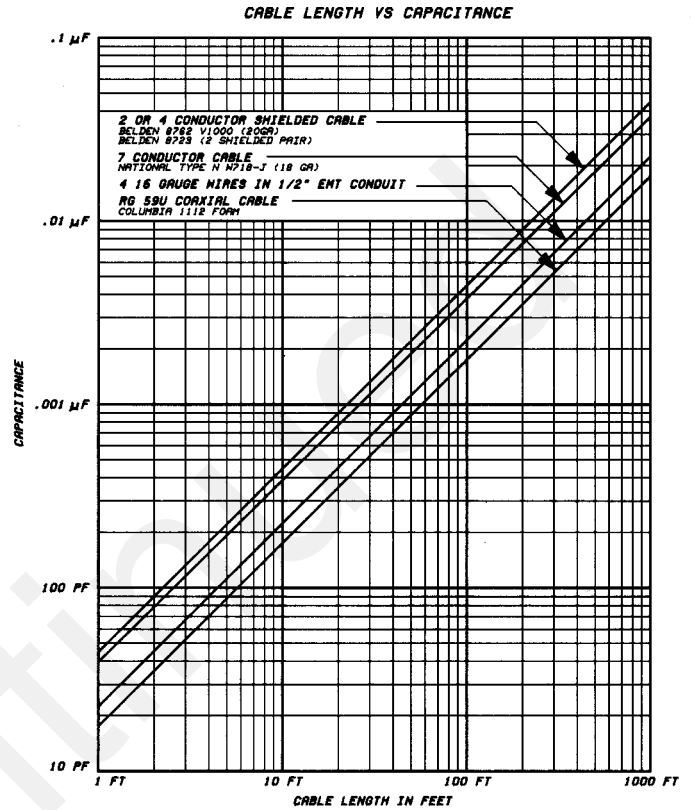
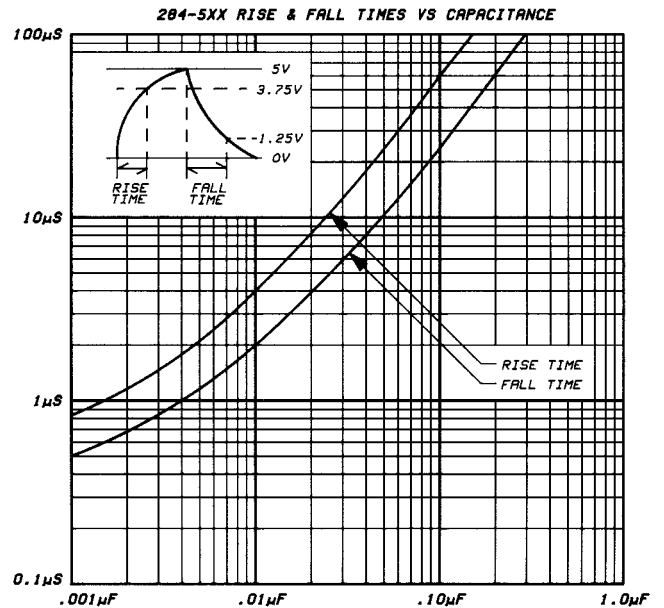

FIG. 9



K-Factor

K-Factor

K-factors represent the number of pulses the transmitter outputs per cubic centimeter (or other engineering unit) of fluid passing through the flow meter. This number is dependent on the flow meter - transmitter combination. MAX indicators can be adjusted to display the desired flow engineering units (ccs, lbs, gallons, quarts, etc.) by using the K-factor.

Flow meters are individually multi-point calibrated at the factory and a graph of the K-factor (which varies slightly with flow rate) provided to the customer. A typical calibration sheet is shown below.

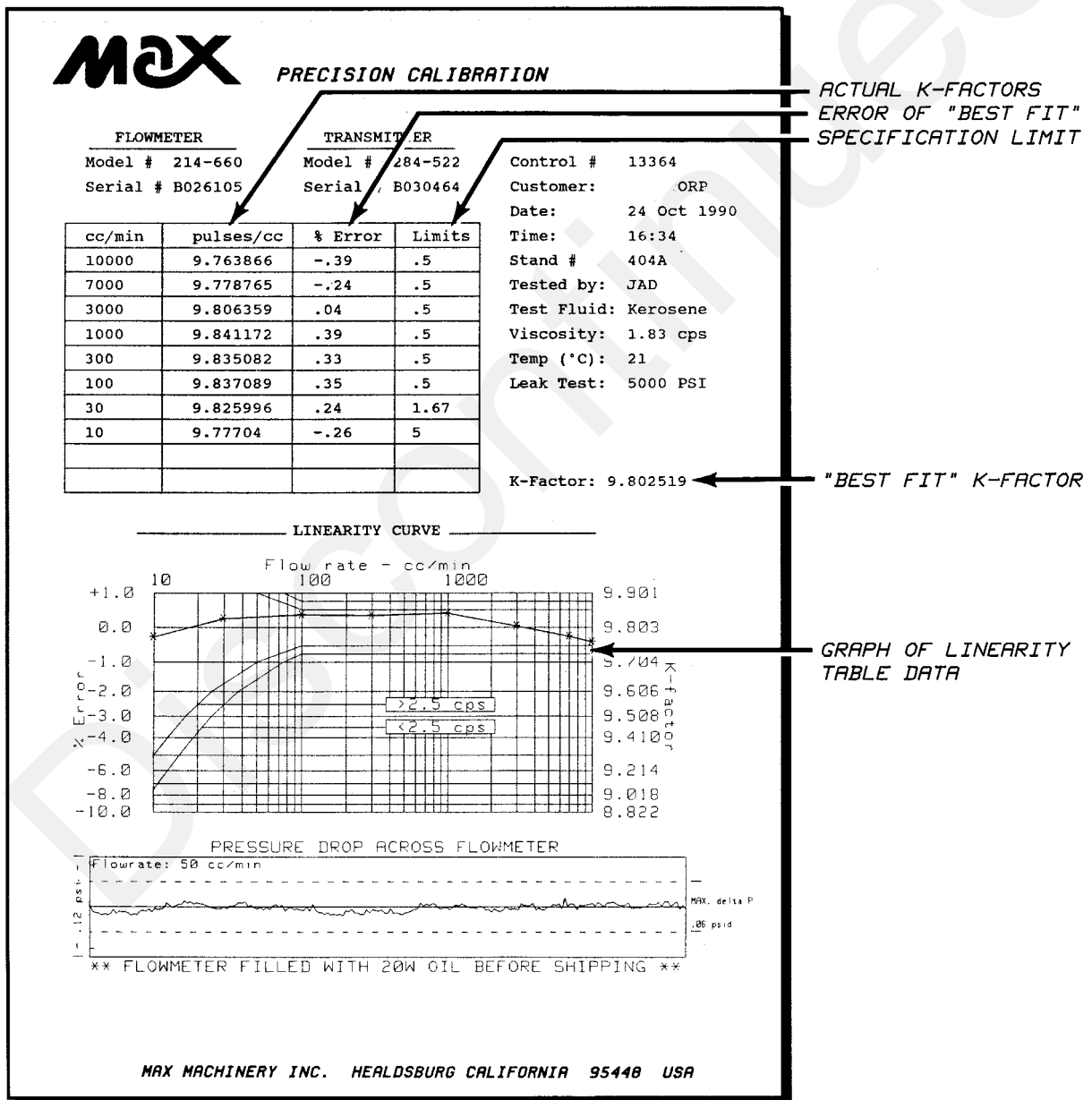
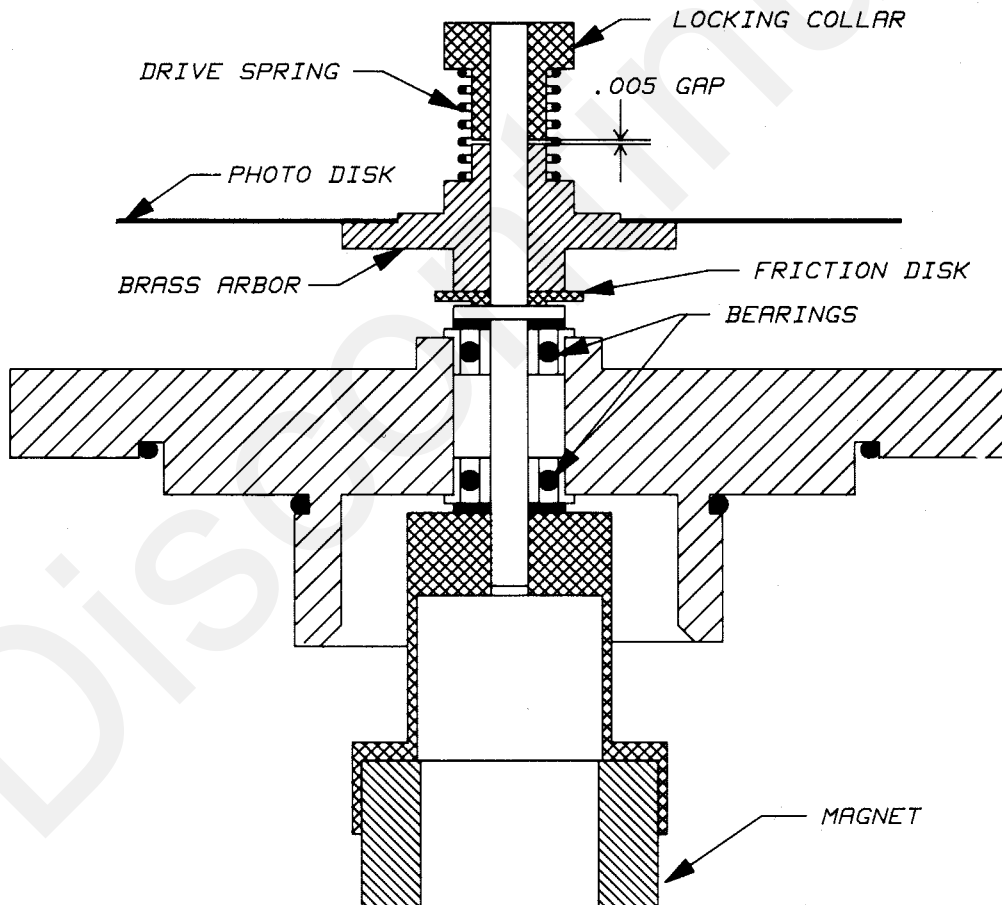

Photo Disk Assembly

Photo Disk Assembly

The Max 210 Piston Series Flow Meters have a sinusoidal type motion superimposed on the overall rotary motion. This motion, when coupled to the 284 through the magnetic drive system, will cause the photo disk of the 284 to oscillate at the systems resonant frequency. For this reason, there is a friction disk mounted between the arbor of the 284 and the photo disk. If the photo disk and shaft assembly is to be disassembled, care should be taken when it is reassembled. A small trace of molybdenum sulfide grease should be placed on the face and bore of the brass arbor which the photo disk is fastened to. The locking collar must not be forced up too tightly against the photo disk. About a 0.005 gap should be left, which allows the disk some freedom of movement. The spring keeps the disk and shaft in synchronization.



General Flow Metering Considerations

Response Rate, Accuracy and Noise

There is always a trade off in a metering system between response rate, accuracy and noise. The three are related such that their product equals a constant. If any one of them is made smaller, the others can be made larger.

In most metering systems, response rate and accuracy are desirable characteristics. To maximize one or both of these parameters, noise should be reduced to a minimum. Once noise has been minimized, there is a trade off between accuracy and response rate.

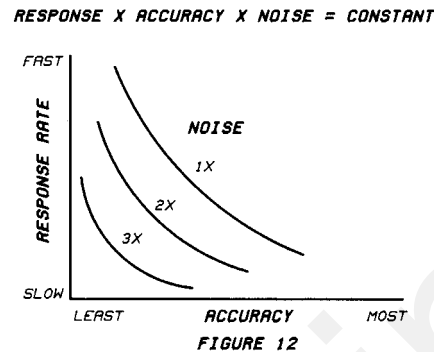

Response Rate: When discussing response rate there are three facets to consider. They are: the response of the flow to a change in the system setpoint, the correction of the flow to an error induced in it, and the response of the flow rate display to a change in flow rates. These responses are all purposely slowed down by filtering or damping so the system only reacts to meaningful flow changes and not to such things as pump pulsations or flow meter ripple. More damping means slower response.

Accuracy: There are three topics to consider when looking at accuracy. The first being the display; which can typically have anywhere from two digits (1 to 99) to 4-1/2 digits (19,999) of information. This equals a resolution of 1% to a maximum of 0.005%, respectively. The display steadiness is also directly related to its accuracy. For instance, a display that jitters from 95 to 105 in a meaningless way is not accurate to one part in 100 (1%) but only to about 10 parts in 100 (10%).

The basic accuracy of the flow meter is a prime consideration. Typically, the accuracy of a positive displacement meter is not as good for a fraction of its cycle as it is for one or more complete cycles. If a system is dampened so that the response rate is longer than the period of one revolution of the meter, the accuracy of the display is increased. The accuracy of the system can never be better than that of the flow meter.

Noise: Noise can be defined as any change in either the fluid flow or the electrical system that is not a meaningful change in the flow rate. For instance, the ripple induced in the flow by a gear or piston pump is noise. The system will typically have to be dampened so that its response time is longer than the tooth to tooth period of the pump. Piston pumps with fewer than three pistons create a particularly large amount of bothersome ripple and result in a very slowly responding system.

General Flow Metering Considerations

Response Rate, Accuracy and Noise (cont.)

All positive displacement flow meters add noise to a flow metering system. The noise is typically of two origins. As the elements of the meter rotate, they require varying amounts of pressure to move (See Fig. 13). This induces pressure fluctuations between the pump (or control valve) and the flow meter. If there is any air trapped in the line, the fluid flow will vary as the air compresses and expands. This will be sensed as a changing flow by the flow meter and the output will contain unwanted ripple or noise. Plumbing in a flow system should be sized and laid out to avoid air being trapped between the flow meter and the flow controlling device (a pump or valve).

The second type of noise that must be considered is a result of flow meter geometry and design. Because of features such as an oval gear, or a piston/crankshaft configuration, or due to manufacturing tolerances, the rotation of the metering elements is not completely uniform. For example, the 210 series meters utilize four pistons connected to a crankshaft. The varying rotational speed of the crankshaft is shown in Fig. 14. To obtain the smoothest output signal, some amount of damping will be necessary at the indicator.

The electronic converter of any meter will add its share of noise. For instance, DC transmitters produce some ripple in their output due to the sinusoidal nature of the induced voltage in the armature coils.

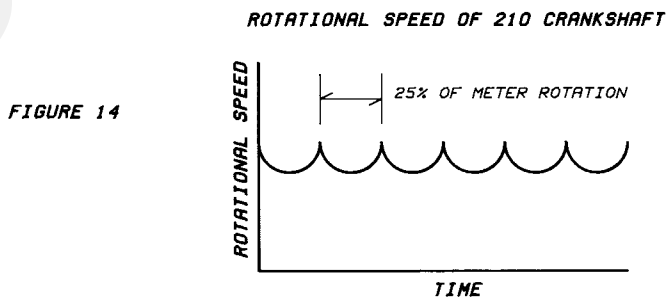
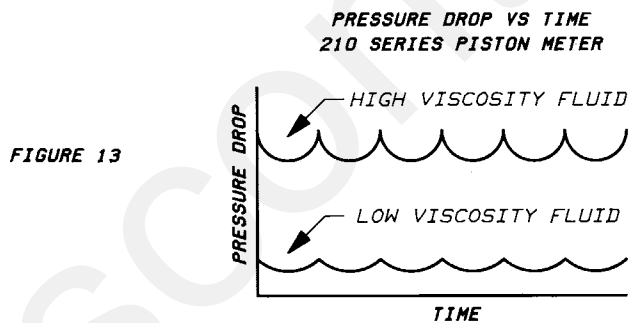

REVISION			
REV	NO	DATE	DESCRIPTION
D	1	1999/10/18	ADD 10 10K RESISTORS, RADUIS ONE CORNER ADD 250 TO THE LENGTH
A		91/04/00	ADD INSTALLATION DRAWING
B		92/08/00	ADD 286-700-009 ASSY
C	1	92/08/00	THE PIN OF SCREWS AND ADD CONNECTOR NUMBERS FOR 1 TRANSLATE VECTOR PLOT TO MESURING

1-340-62425
2-037-20700
1-340-62030
2-037-18800

FOR PCA 286-700-009: INSTALL 3 1K RESISTORS
FOR PCA 286-700-010: INSTALL 3 2.2K RESISTORS

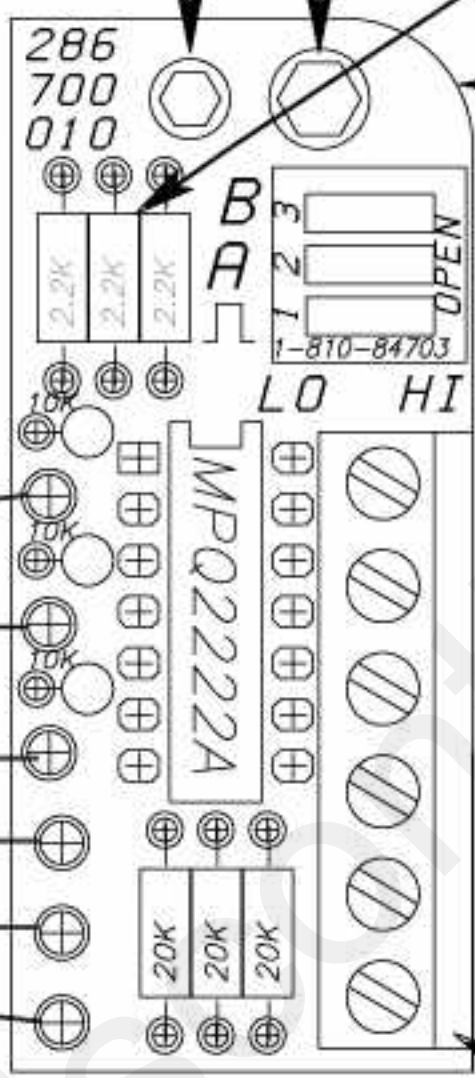

286-700-011 PCB

1-810-84703

1-180-96706

PHASE B (BLUE)
PHASE A (ORANGE)
OUTPUT (WHITE)
POWER (RED)
COMMON (BLACK)
GROUND (GREEN)

PHASE B
PHASE A
OUTPUT
PWR
COM
GND

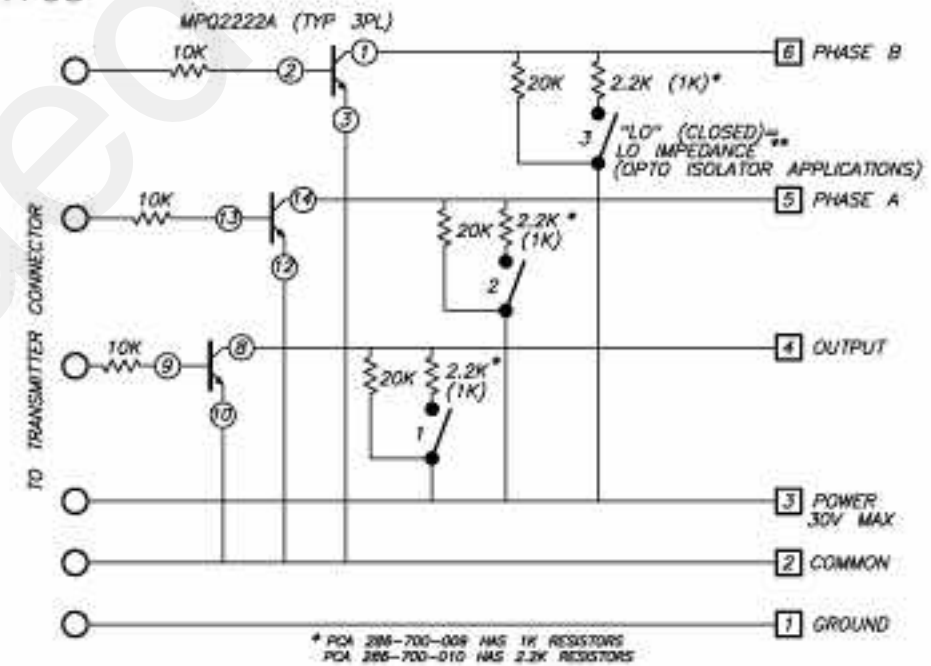

* PCA 286-700-009 HAS 1K RESISTORS
PCA 286-700-010 HAS 2.2K RESISTORS

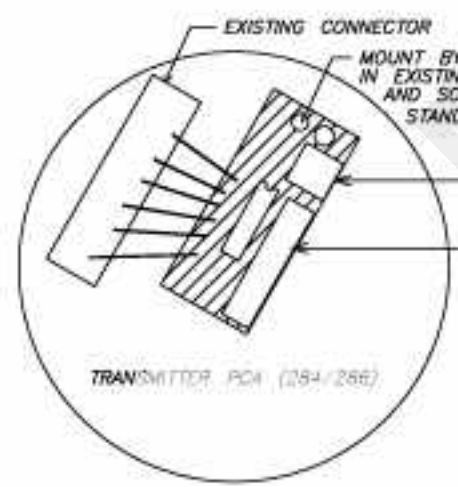
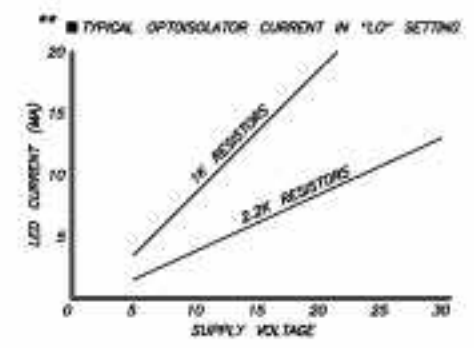

SELECT "H" FOR LOGIC (CMOS) INTERFACE.
SELECT "LO" FOR OPTOISOLATOR INTERFACE.
(CHECK GRAPH & OPTO SPECS.)
LEAVE UNUSED OUTPUTS IN "H".
MAKE EXTERNAL CONNECTIONS HERE

TOP ASSIST	WHERE USED	WHERE USED CONT
PR BY EMB	286-700-011, 901-000-200, 286-700-009	
MATERIAL	DECIMAL X .000 XX .001 XXX .003 XXXX .0005	<p>*** COPYRIGHT ***</p> <p>THIS DOCUMENT IS THE PROPERTY OF MAX MACHINERY, INC. AND CONTAINS CONFIDENTIAL AND TRADE SECRET INFORMATION OF MAX MACHINERY, INC. THIS DOCUMENT MAY BE TRANSFERRED FROM THE CUSTODY OR CONTROL OF MAX MACHINERY, INC. ONLY AS AUTHORIZED BY MAX MACHINERY, INC. AND THEN ONLY BY WAY OF LOAN FOR LIMITED PURPOSES. IT MAY NOT BE REPRODUCED IN WHOLE OR IN PART AND MUST BE RETURNED TO MAX MACHINERY UPON REQUEST AND IN ALL EVENTS UPON COMPLETION OF PURPOSE OF THE LOAN. NEITHER THIS DOCUMENT NOR THE INFORMATION IT CONTAINS MAY BE USED BY OR DISCLOSED TO PERSONS NOT HAVING A NEED FOR SUCH USE OR DISCLOSURE CONSISTENT WITH THE PURPOSE OF THE LOAN WITHOUT PRIOR WRITTEN CONSENT OF MAX MACHINERY, INC.</p>
SIZE	FRACTIONAL #XXX HOLES .010 -.000 ANGULAR 11°	
FINISH	SURFACE FINISH 04 BREAK ALL EDGES .010 TO .015	
	TOLERANCES EXCEPT AS NOTED	
<p>MAXTM MAX MACHINERY 1420 HEALDSBURG AVE. HEALDSBURG, CA 95448</p> <p>CUSTOMER: PCA DRAWN: EMB DESIGNER: JEB DESIGNER 2</p> <p>DESCRIPTION: PCA VOLTAGE LEVEL SHIFTER PULSE XMTRS</p> <p>SCALE: 4:1 DATE: 91/01/00</p>		<p>DATE: 91/01/00</p> <p>286-700-010</p>

REVISION		
REV.	DATE	DESCRIPTION
J	2/90	INITIAL DESIGN
I	10/89	U1 was 74C04 to 74C14
H	9/89	CORRECT UB pin 10-8
G	8/89	correct ref des,chg sensor sch only
F	6/89	REDESIGN PCB REV C

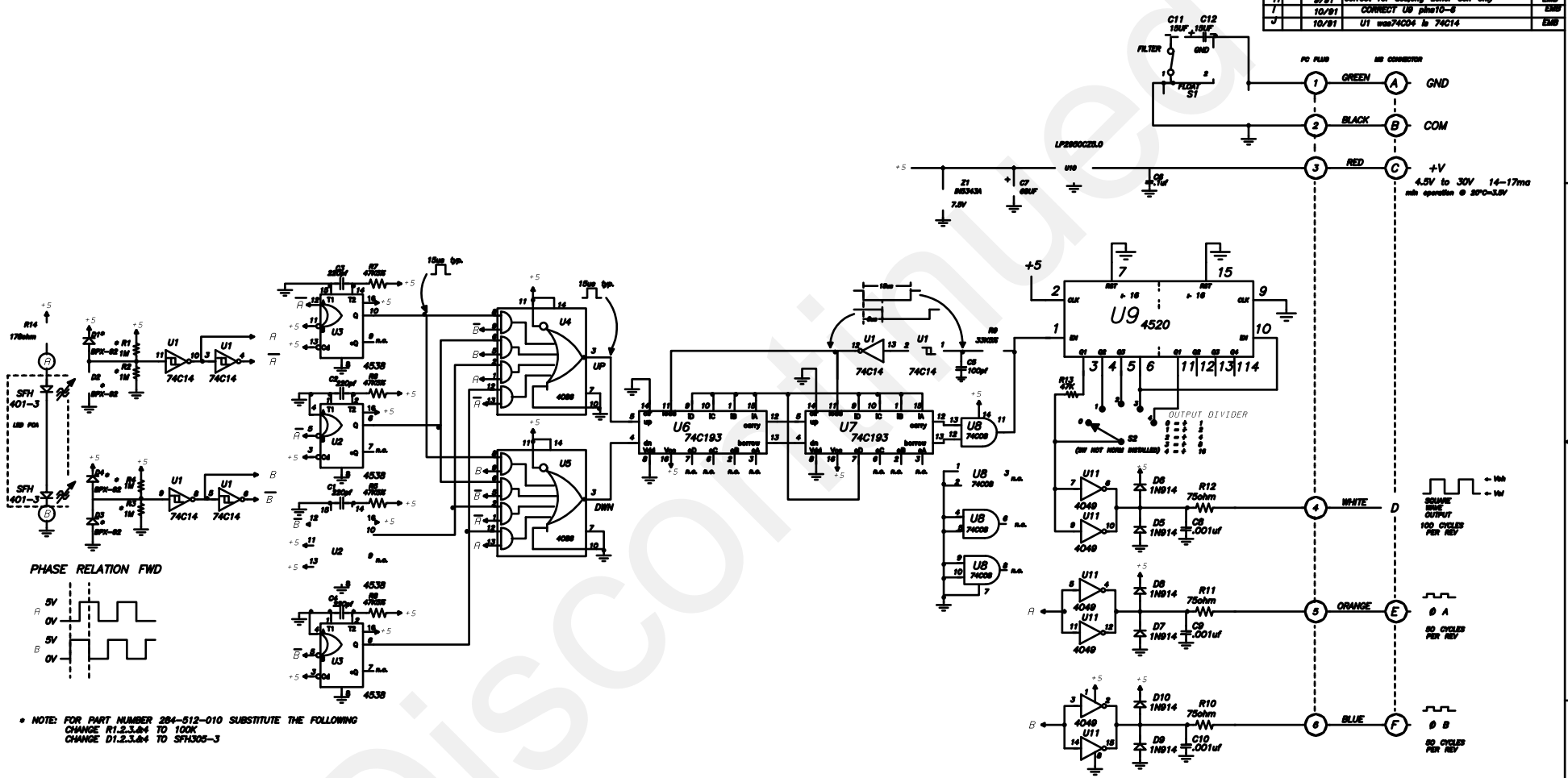
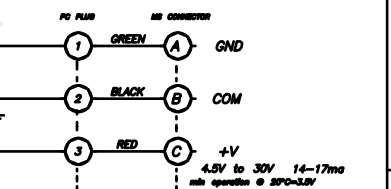

MAX MAX MACHINERY 1820 HEALDSBURG AVE. HEALDSBURG, CA 95648	MAX MACHINERY 1820 HEALDSBURG AVE. HEALDSBURG, CA 95648 TEL: (916) 486-7500 FAX: (916) 486-7501 WWW: WWW.MAXMACH.COM
MAX MACHINERY 1820 HEALDSBURG AVE. HEALDSBURG, CA 95648	MAX MACHINERY 1820 HEALDSBURG AVE. HEALDSBURG, CA 95648
MAX MACHINERY 1820 HEALDSBURG AVE. HEALDSBURG, CA 95648	MAX MACHINERY 1820 HEALDSBURG AVE. HEALDSBURG, CA 95648
MAX MACHINERY 1820 HEALDSBURG AVE. HEALDSBURG, CA 95648	MAX MACHINERY 1820 HEALDSBURG AVE. HEALDSBURG, CA 95648
MAX MACHINERY 1820 HEALDSBURG AVE. HEALDSBURG, CA 95648	MAX MACHINERY 1820 HEALDSBURG AVE. HEALDSBURG, CA 95648

PULSE XMITR SCH

284-510-200

REV		DATE	DESCRIPTION	BY
K	1	2003/06/11	CORRECTED MODEL 030 TERMINAL CONN (784-4 WAS 184-5)	E
F	1	07/07	ADDED NEW INSTRS AND INSTRUMENTS	JE
F	1	06/11	ADDED NEW INSTRUMENTS	JE
G	1	04/06/09	WIRING DIAGRAMS ADDED TO 181-000-251, CORRECTED PCA CONNECTIONS, ADDED MODEL 120	EN
H	1	05/12/21	CORRECTED 286-723 WIRING DIAGRAM TO COM +V WIRE	EN
J	1	05/06/21	REMOVED WIRES FROM E & F CONNECTORS TO AMPHENOL E & F	LN
J	1	2002/12/12	REMOVED 286-723 & 723 ADDED 286-303 & ADDED MODEL 121	RG

TRANSMITTER MODELS

234-1X0
234-2X0

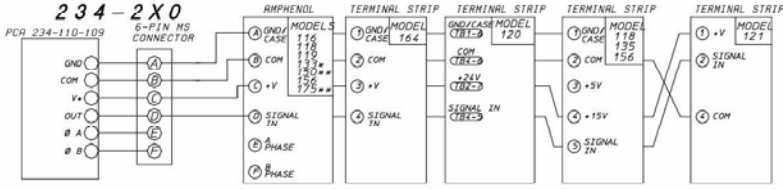

* MUST USE PCA 133-210-008 FREQ/DIC
** ONLY MODELS WHICH ACCEPT A & B PHASES

284-5X2

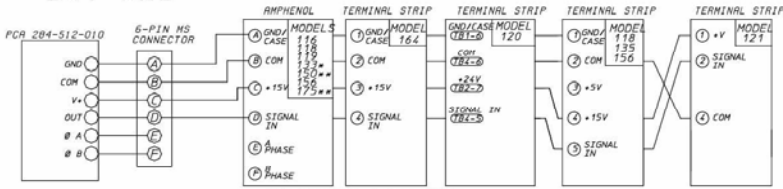

* MUST USE PCA 133-210-008 FREQ/DIC
** ONLY MODELS WHICH ACCEPT A & B PHASES

284-7X2

(INTRINSICALLY SAFE TRANSMITTER)

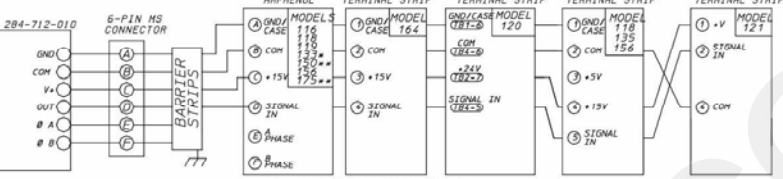

* MUST USE PCA 133-210-008 FREQ/DIC
** ONLY MODELS WHICH ACCEPT A & B PHASES

286-3X3

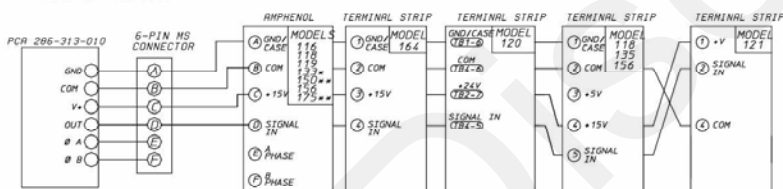

* MUST USE PCA 133-210-008 FREQ/DIC
** ONLY MODELS WHICH ACCEPT A & B PHASES

NOTE: NOT ALL TRANSMITTER MODELS REQUIRE AN 'MS' TYPE CONNECTOR.

TRANSMITTER MODELS

INSTRUMENT MODELS

272-5X5

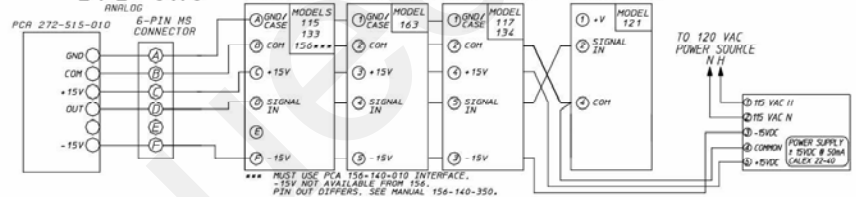

* MUST USE PCA 156-140-010 INTERFACE.
** 15V NOT AVAILABLE FROM 154.
*** PIN OUT DIFFERS. SEE MANUAL 156-140-350.

272-5X7

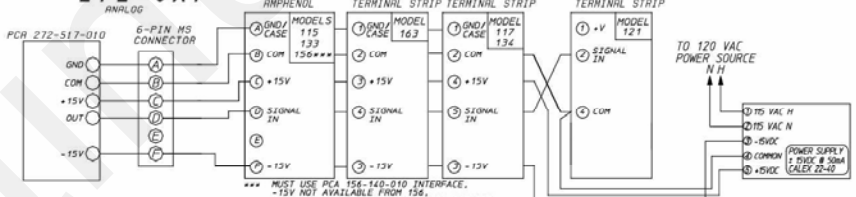

* MUST USE PCA 156-140-010 INTERFACE.
** 15V NOT AVAILABLE FROM 156.
*** PIN OUT DIFFERS. SEE MANUAL 156-140-350.

272-5X8

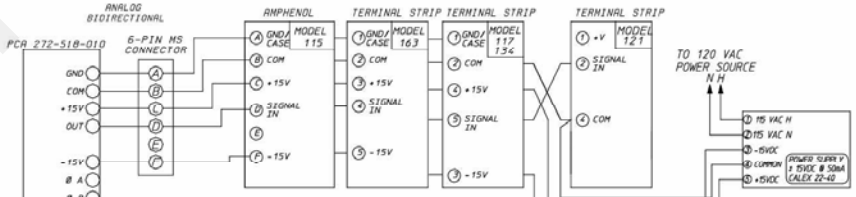

289-7X3

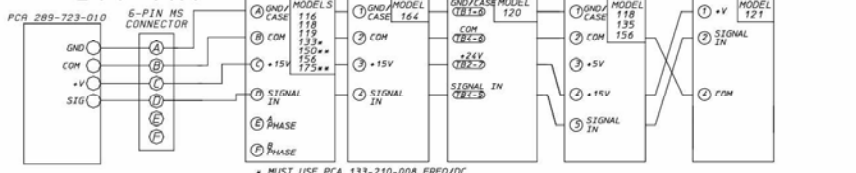

* MUST USE PCA 133-210-008 FREQ/DIC

TOP Assy	WHERE USED	WHERE USED CONT
Pin or GND		
MATERIAL	<p>RECORDED STANDARD TOLERANCES J1 .0000 J2 .0000 J3 .0000 J4 .0000</p>	<p>*** COPYRIGHT *** THIS DOCUMENT IS THE PROPERTY OF MAX MACHINERY, INC. AND CONTAINS CONFIDENTIAL AND TRADE SECRET INFORMATION. IT IS LOANED TO YOU BY MAX MACHINERY, INC. THIS DOCUMENT MAY BE TRANSFERRED FROM THE CUSTODY OF COMPANY OF MAX MACHINERY, INC. ONLY AS AUTHORIZED BY MAX MACHINERY, INC. AND THEN ONLY BY WAY OF LOAN FOR LIMITED PURPOSES. IT MAY NOT BE REPRODUCED IN WHOLE OR IN PART AND MUST BE RETURNED TO MAX MACHINERY, INC. UPON REQUEST AND IN ALL EVENTS UPON COMPLETION OF PURPOSE OF THE LOAN. NEITHER THIS DOCUMENT NOR THE INFORMATION IT CONTAINS MAY BE USED BY OR DISCLOSED TO ANY PERSON NOT HAVING A NEED FOR SUCH USE OR DISCLOSURE CONSISTENT WITH THE PURPOSE OF THE LOAN WITHOUT PRIOR WRITTEN CONSENT OF MAX MACHINERY, INC.</p>
DATE	<p>DATE 05/09/11</p>	<p>SCALE NONE</p>
DESIGNER	<p>DESIGNER SCH</p>	<p>DESIGNER 2 SCH</p>
DATE	<p>DATE 05/09/11</p>	<p>SCALE NONE</p>
DESIGNER	<p>DESIGNER SCH</p>	<p>DESIGNER 2 SCH</p>

MAX MAX MACHINERY
1420 HEALDSBURG AVE., HEALDSBURG, CA 95448

TRANSMITTER CABLE INTERCONNECT

181-000-250